

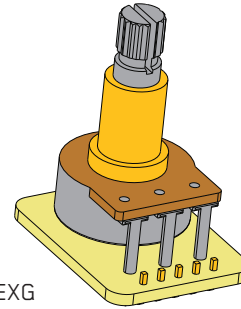

0230-0164FB

PO BOX 4394  
SANTA ROSA, CA  
95402 USA

P (707) 525-9941  
F (707) 575-7046  
EMGPICKUPS.COM



EXG

## INSTALLATION INFORMATION EMG MODEL: EXG (ACTIVE/PASSIVE PICKUP INPUTS)

### SPECIFICATIONS

Input Impedance (Ohms)	250K
Input Referred Noise	-130dbV
Output Impedance (Ohms)	2K
Current @ 9V (Microamps)	750
Battery Life (Hours)	200
Maximum Supply (Volts DC)	18

### INCLUDED:

- 1 EXG Control
- 1 Battery Clip with Buss Connector
- 1 Stereo Output Jack (Battery Switching)
- 2 Interconnect cables

### GENERAL OPERATION:

The EXG is an active EQ circuit for guitar that simultaneously increases both low and high frequencies while decreasing mid-range. The graph below illustrates the effect of the EXG. The thick black line displays the effect with the control all the way up (clockwise). The flat black line illustrates the effect with the control all the way down (counter-clockwise) in the bypass mode. The EXG is continuously variable from flat to maximum effect. The EXG is wired in series with the signal path, so there is an input and output. The EXG has buffered inputs and can be used with passive pickups.

### Frequency Response: EMG-EXG

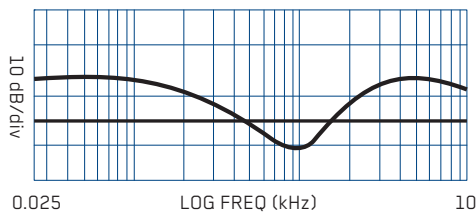

### Dimensions:

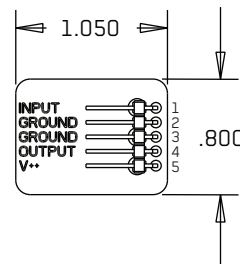
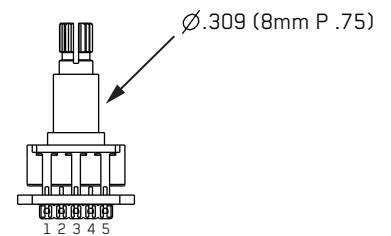
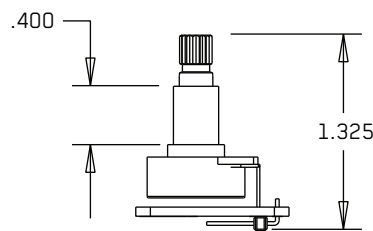

Connector for EMG Active Tone controls and accessories.

- Pin 1 Input
- Pin 2 Ground for Input
- Pin 3 Ground for Output
- Pin 4 Output
- Pin 5 V+ Supply

### WARRANTY

All EMG Pickups and accessories are warranted for a period of two years. This warranty does not cover failure due to improper installation, abuse or damage. If upon examination the pickup is determined to be defective, a replacement will be made. Warranty replacement products are covered by this same warranty. This

**Installation Instructions:**

**EMG Model: EXG**

Like all EMG Accessory products the EXG uses the 5-pin header as a standard. Diagram #1 to the right shows how the plug-in connectors are installed. Be sure to reverse the input connector as shown.

Since there are a variety of installations in which the EXG can be installed it is impossible to show every installation in this data sheet. Some of the simpler installations have been chosen. More diagrams are available at our website <http://www.emgpickups.com>. Diagrams #2 and #3 illustrate installations that have a single pickup and do not use a selection switch.

Page 3 has diagrams that have 2 pickups and a selection switch. Page 4 has diagrams that have 3 Pickups and use the B161 five-position selection switch/buss. If you have the B161, refer to that data sheet where more options regarding 3-pickup instruments are available.

Keep in mind that all of the EMG Accessory controls can be substituted for one another since they all have buffered inputs and utilize the same 5-pin connector. So, if you decide you would rather use the SPC instead of the EXG, simply unplug the EXG and replace it with the SPC.

All of the EMG Active controls use the same 5-pin connector shown below.

Note: Reversed connector! Pins 1 and 2 are reversed. Make sure the connectors are plugged on as shown.

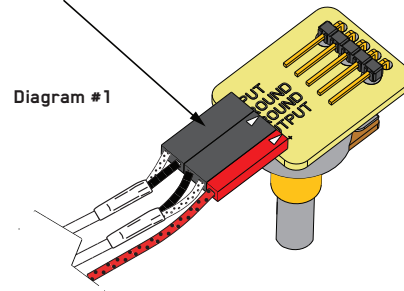

**Diagram #2**

- One Pickup
- One Volume
- One EXB

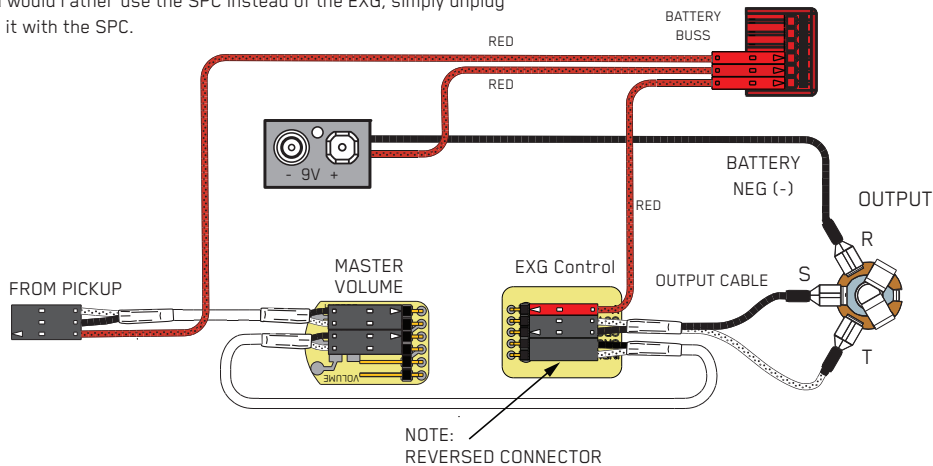

**Diagram #3**

- One Pickup
- One Volume
- One Master Tone (Passive)
- One EXB

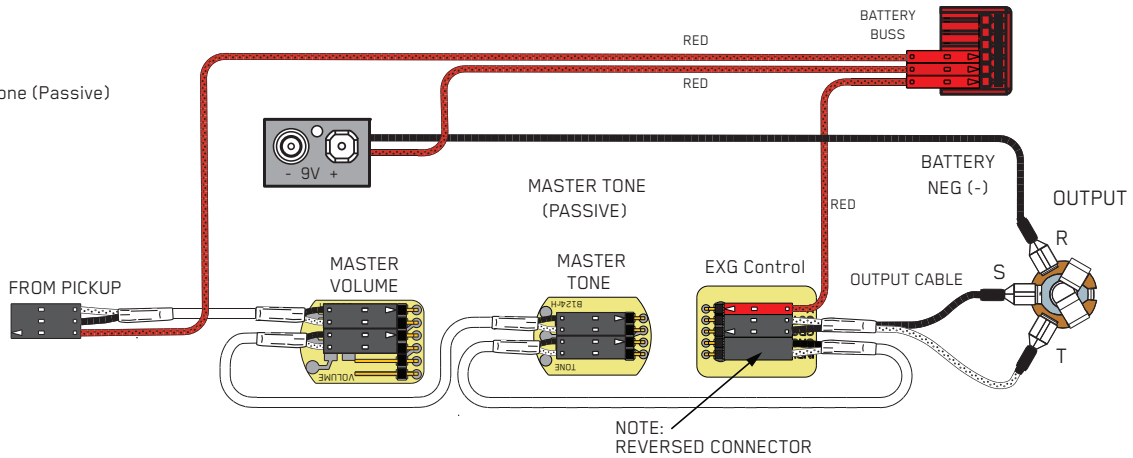

**Diagram #4**

- Volume / Volume
- EXB Control

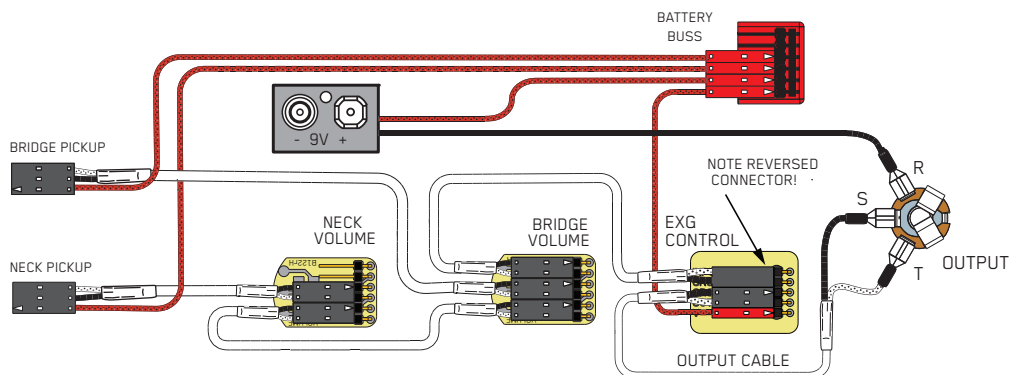

## 2 Pickup Guitars using a selection switch:

Diagrams #4 and #5 show the pickups connected to the B245 Pickup Buss.

To learn more about the B245 Pickup Buss, be sure to go to the EMG Website: <http://www.emgpickups.com>. More diagrams are available at the EMG website.

The EXG or any EMG Active Tone Control is shown following the pickup buss and then to the output jack. A master volume could easily follow the SPC before the output jack.

### Diagram #5

2 Pickups  
Toggle Style Switch  
Volume each Pickup (Volumes are independent)  
EXG Control

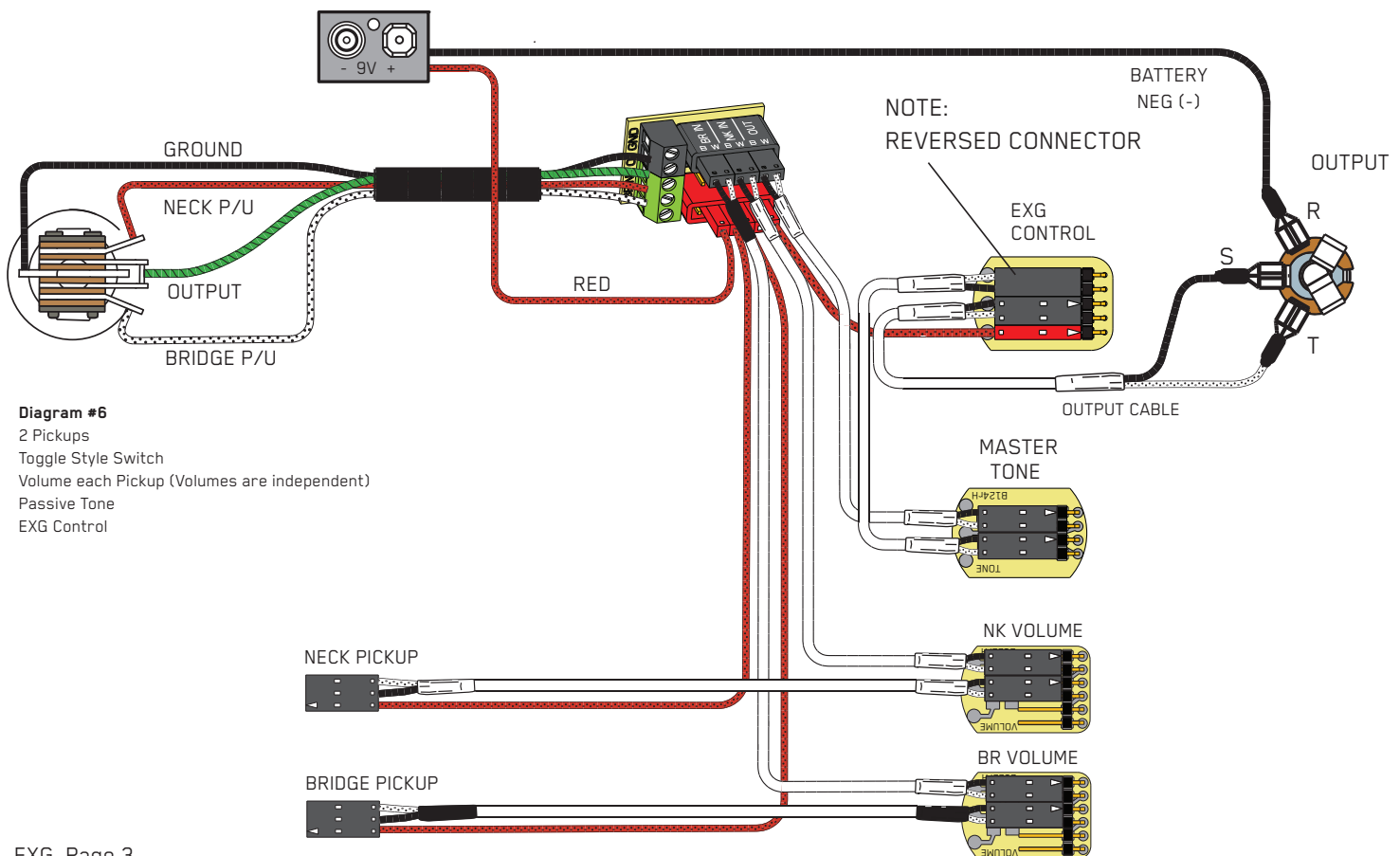
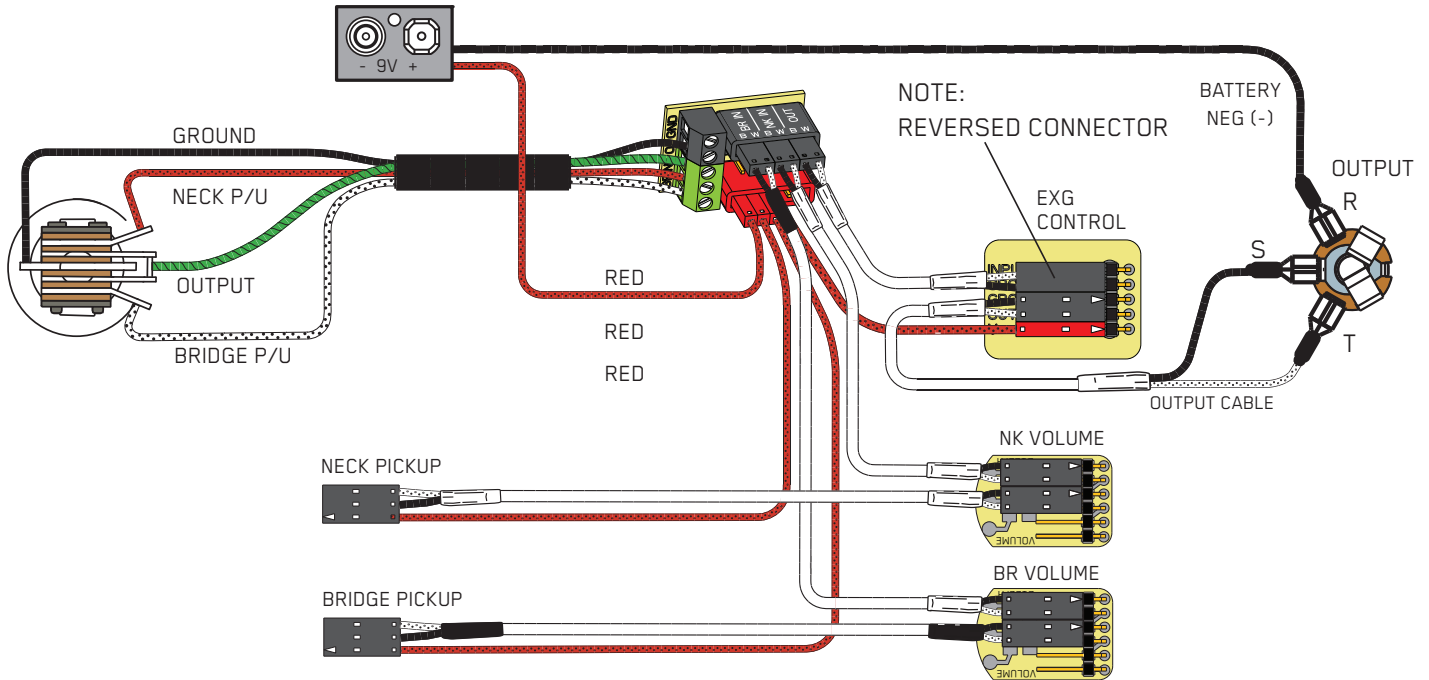

### Diagram #6

2 Pickups  
Toggle Style Switch  
Volume each Pickup (Volumes are independent)  
Passive Tone  
EXG Control

### 3 Pickup Guitars using a selection switch:

The EXG Control is larger than EMG's other accessories, so it is shown installed in Strat\* installations in the middle control position with the tone control shown in the last control position.

Diagrams #7, #8, and #9 show a typical installation with a Volume/Tone/EXG in a "daisy-chain" series wiring. The only difference between the diagrams is the order in which the controls are wired. All diagrams yield the same results. The diagrams have been edited to show the EXG input, output, and power (9V+). The pickup inputs, battery, and "ring" contact to the jack have been omitted for clarity.

All diagrams also show the B161 5-Position switch buss. To learn more about the B161 5-Position switch Buss, go to the EMG Website: <http://www.emgpickups.com>.

#### Refer to Diagram #6

Start by installing the EXG as shown in Diagram #7.

- 1) Plug a coax cable from the switch output to the Volume control.
- 2) Plug a coax cable from the Volume control to the Tone control.
- 3) Plug a coax cable from the Tone control to the input of the EXG.

Be sure to reverse the connector on the input of the EXG as shown.

- 4) Plug the output cable from the EXG to the output jack.
- 5) Plug the Red wire from the EXG to one of the supply pins on the B161 Switch Buss.

Be sure the 3 shunts are installed on the bypass header of the B161 switch or you won't get any output from the guitar.

#### Refer to Diagram #7

Start by installing the EXG as shown in Diagram #8.

- 1) Plug a coax cable from the switch output to the Tone control.
- 2) Plug a coax cable from the Tone control to the input of the EXG.

Be sure to reverse the connector on the input of the EXG as shown.

- 3) Plug a coax cable from the output of the EXG to the Volume control.
- 4) Plug the output cable from the Volume control to the output jack.
- 5) Plug the Red wire from the EXG to one of the supply pins on the B161 Switch Buss.

Be sure the 3 shunts are installed on the bypass header of the B161 switch or you won't get any output from the guitar.

#### Refer to Diagram #8

Diagram #8 shows 2 active controls installed. This would be similar to the X Series Pickups that use an active tone (VLPF) and adding the EXG Control.

Start by installing the EXG as shown in Diagram #9.

- 1) Plug a coax cable from the switch output to the Volume control.
- 2) Plug a coax cable from the Volume control to the input of the EXG.

Be sure to reverse the connector on the input of the EXG as shown.

- 3) Plug a coax cable from the output of the EXG to the input of the VLPF.
- 4) Plug the output cable from the VLPF to the output jack.

Be sure to reverse the connector on the input of the VLPF as shown.

5) Plug the Red wires from both the VLPF and EXG to the extra 9V+ supply pins on the B161 Switch Buss.

Be sure the 3 shunts are installed on the bypass header of the B161 switch or you won't get any output from the guitar.

Diagram #7  
Volume Control  
EXG Control  
Tone (Passive)

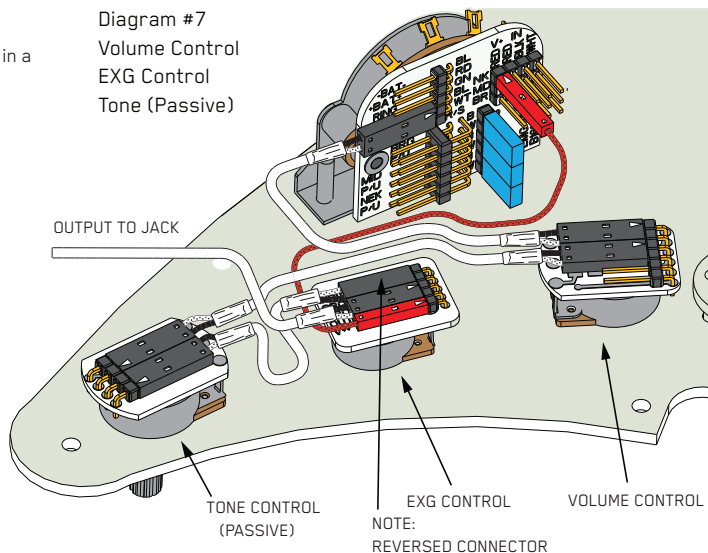

Diagram #8  
Tone Control (Passive)  
EXG Control  
Volume Control

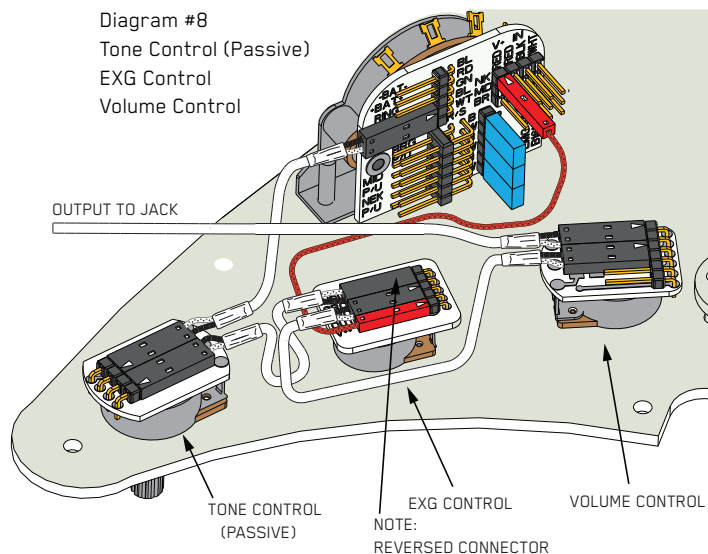

Diagram #9  
Volume Control  
EXG Control  
Tone (Active VLPF)

