

TC2290-DT

Legendary Dynamic Delay Plug-In with Dedicated Desktop Interface and Signature Presets

Table of Contents

- Important Safety Instructions 3**
- Legal Disclaimer 3**
- Limited warranty 3**
- 1. Introduction 4**
- 2. Plug-in Installation..... 4**
 - 2.1 Installation on a PC..... 4
 - 2.2 Installation on a Mac 4
- 3. Connection and Setup..... 5**
- 4. Hardware and Plug-in Controls..... 8**
 - 4.1 Hardware Controls..... 8
 - 4.2 Plug-in Controls 10
- 5. Operation 12**
 - 5.1 Delay Parameters 12
 - 5.2 Modulation Effects..... 13
- 6. Presets 15**
- 7. Hardware Unit Software Updates 16**
- 8. Specifications..... 17**
- 9. Signal Flow Diagram 18**

EN Important Safety Instructions



Terminals marked with this symbol carry electrical current of sufficient magnitude to constitute risk of electric shock.

Use only high-quality professional speaker cables with ¼" TS or twist-locking plugs pre-installed. All other installation or modification should be performed only by qualified personnel.



This symbol, wherever it appears, alerts you to the presence of uninsulated dangerous voltage inside the enclosure - voltage that may be sufficient to constitute a risk of shock.



This symbol, wherever it appears, alerts you to important operating and maintenance instructions in the accompanying literature. Please read the manual.



Caution

To reduce the risk of electric shock, do not remove the top cover (or the rear section). No user serviceable parts inside. Refer servicing to qualified personnel.



Caution

To reduce the risk of fire or electric shock, do not expose this appliance to rain and moisture. The apparatus shall not be exposed to dripping or splashing liquids and no objects filled with liquids, such as vases, shall be placed on the apparatus.



Caution

These service instructions are for use by qualified service personnel only. To reduce the risk of electric shock do not perform any servicing other than that contained in the operation instructions. Repairs have to be performed by qualified service personnel.

1. Read these instructions.
2. Keep these instructions.
3. Heed all warnings.
4. Follow all instructions.
5. Do not use this apparatus near water.
6. Clean only with dry cloth.
7. Do not block any ventilation openings. Install in accordance with the manufacturer's instructions.
8. Do not install near any heat sources such as radiators, heat registers, stoves, or other apparatus (including amplifiers) that produce heat.

9. Do not defeat the safety purpose of the polarized or grounding-type plug. A polarized plug has two blades with one wider than the other. A grounding-type plug has two blades and a third grounding prong. The wide blade or the third prong are provided for your safety. If the provided plug does not fit into your outlet, consult an electrician for replacement of the obsolete outlet.

10. Protect the power cord from being walked on or pinched particularly at plugs, convenience receptacles, and the point where they exit from the apparatus.

11. Use only attachments/accessories specified by the manufacturer.



12. Use only with the cart, stand, tripod, bracket, or table specified by the manufacturer, or sold with the apparatus. When a cart is used, use caution when moving the cart/apparatus combination to avoid

injury from tip-over.

13. Unplug this apparatus during lightning storms or when unused for long periods of time.

14. Refer all servicing to qualified service personnel. Servicing is required when the apparatus has been damaged in any way, such as power supply cord or plug is damaged, liquid has been spilled or objects have fallen into the apparatus, the apparatus has been exposed to rain or moisture, does not operate normally, or has been dropped.

15. The apparatus shall be connected to a MAINS socket outlet with a protective earthing connection.

16. Where the MAINS plug or an appliance coupler is used as the disconnect device, the disconnect device shall remain readily operable.



17. Correct disposal of this product: This symbol indicates that this product must not be disposed of with household waste, according to the WEEE Directive (2012/19/EU) and your national law. This product should be taken to a collection center licensed for the recycling of waste electrical and electronic equipment (EEE). The mishandling of this type of waste could have a possible negative impact on the environment and human health due to potentially hazardous substances that are generally associated with EEE. At the same time, your cooperation in the correct disposal of this product will contribute to the efficient use of natural resources. For more information about where you can take your waste equipment for recycling, please contact your local city office, or your household waste collection service.

18. Do not install in a confined space, such as a book case or similar unit.

19. Do not place naked flame sources, such as lighted candles, on the apparatus.

20. Please keep the environmental aspects of battery disposal in mind. Batteries must be disposed-of at a battery collection point.

21. Use this apparatus in tropical and/or moderate climates.

LEGAL DISCLAIMER

MUSIC Tribe accepts no liability for any loss which may be suffered by any person who relies either wholly or in part upon any description, photograph, or statement contained herein. Technical specifications, appearances and other information are subject to change without notice. All trademarks are the property of their respective owners. MIDAS, KLARK TEKNIK, LAB GRUPPEN, LAKE, TANNOY, TURBOSOUND, TC ELECTRONIC, TC HELICON, BEHRINGER, BUGERA and COOLAUDIO are trademarks or registered trademarks of MUSIC Tribe Global Brands Ltd. © MUSIC Tribe Global Brands Ltd. 2018 All rights reserved.

LIMITED WARRANTY

For the applicable warranty terms and conditions and additional information regarding MUSIC Tribe's Limited Warranty, please see complete details online at musictri.be/warranty.

1. Introduction

Read this manual to learn how to install and use your TC Electronic TC2290 delay unit. This manual is only available in PDF format from the TC Electronic website. To get the most from this manual, please read it from start to finish, or you may miss important information.

To download the most current version of this manual, visit the web page:

www.tcelectronic.com/Categories/c/Tcelectronic/Downloads

If you still have questions about your TC Electronic product after reading its manual, please get in touch with TC Support:

www.tcelectronic.com/brand/tcelectronic/support

2. Plug-in Installation

Visit www.tcelectronic.com/tc2290-dt/support/ to download the installer file. The plug-in is free and can be installed on an unlimited number of computers, but does require the TC2290 hardware unit to operate the main parameters such as delay time.

Select the Mac or PC version and save the file to your hard drive. Use the correct 32 or 64 bit version that matches your operating system. The latest firmware for the TC2290 unit will be included in the software as well.

2.1 Installation on a PC

Open the zip file and double click the executable file. If you get a security warning, click 'Run'.

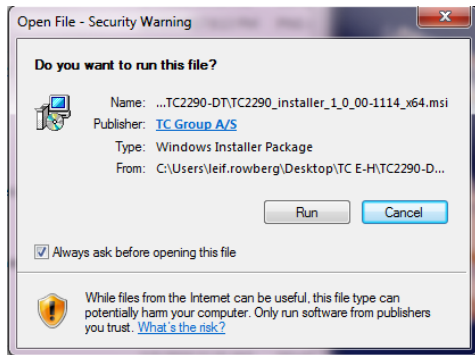

Accept the license agreement and click 'Next'.

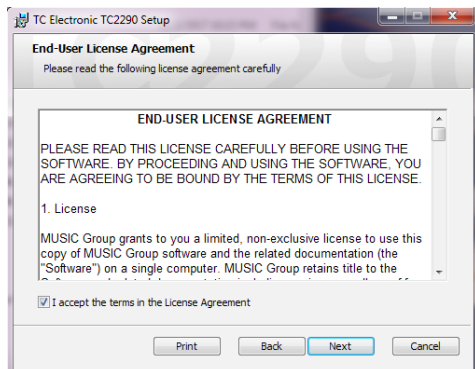

Select which VST and/or AAX components you want to install. Pro Tools uses AAX and most other DAW programs use VST. The installer will offer a default location to save the file, but you can choose another location by clicking the 'Browse' button.

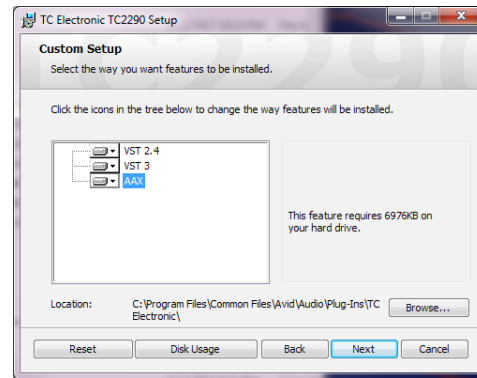

Click 'Next' to begin the installation. When installation is complete, click 'Finish'.

2.2 Installation on a Mac

Open the zip folder and double click the installer icon.

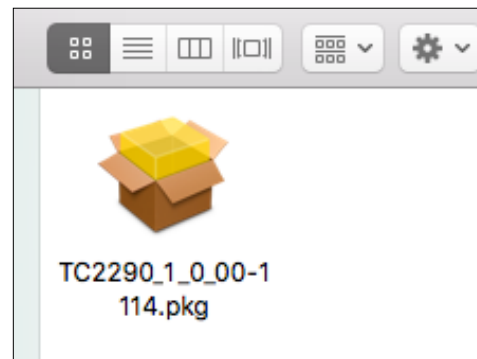

Proceed through the prompts to begin installation.

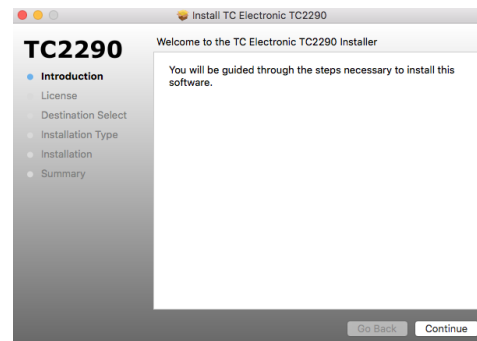

Click 'Continue' and accept the license agreement.

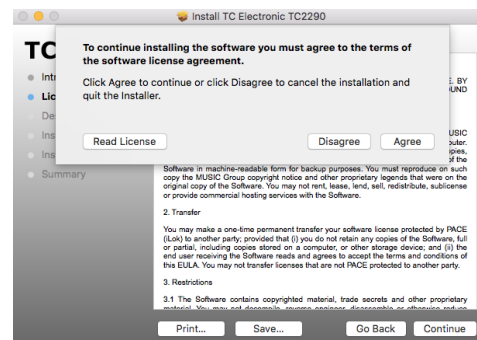

A default location will be selected for installation, or you can select another folder manually. If you have administrator authorization in place, you will need to enter your password before beginning installation.

3. Connection and Setup

Getting the TC2290 up and running couldn't get any easier. Plug the included USB cable into the unit's rear micro-USB port, and connect the other end to a free USB port on your computer. The TC2290 is bus powered so no other power cables are necessary, and no additional drivers need to be manually installed.

The TC2290 is built to work with a USB hub, but not all hubs are supported. If the TC2290 fails to power on or doesn't connect to the plug-in, try connecting directly to a USB port instead of the hub.

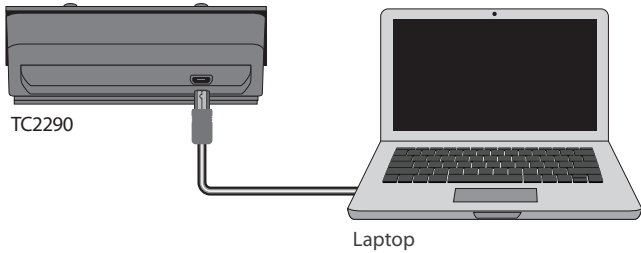

The TC2290 should light up upon successful connection. You can now apply the plug-in to a channel in your DAW to begin using the effect. This process may vary slightly depending on your software, but generally should require these steps:

- Select a channel or bus in your DAW to which you would like to add the effect.
- Access the mixer page where you should see a section dedicated to effect slots.



- Open the menu where you can select from a list of effect types, which probably includes many stock plugins that are included with the DAW. There should be a submenu to view general VST/AU/AAX options.

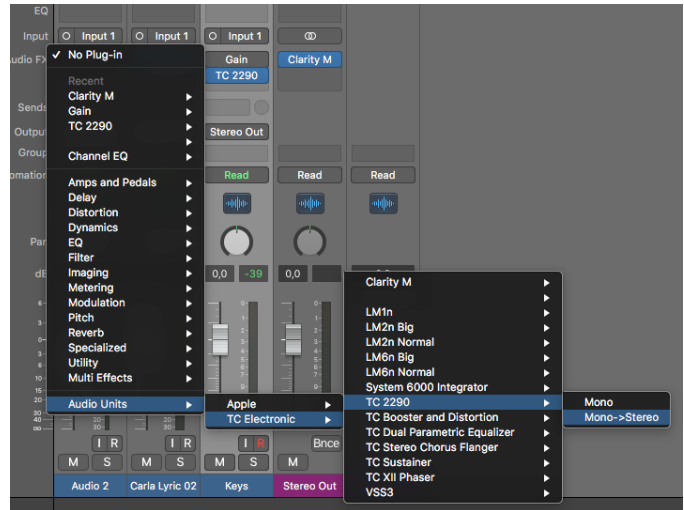
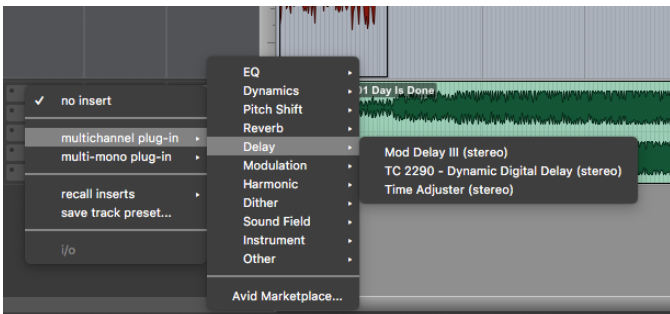

- The plug-in will likely be found in a dedicated TC Electronic folder. Select the TC2290 and it will now be added to the signal chain.

Insert vs Aux Effect

The TC2290 can be inserted directly into an effect slot on a single channel, as described above, which passes the entire signal through the effect. In this case, note that the direct input signal becomes mono before it is panned, either statically or modulated. This occurs when the PAN/DYN section DIRECT button is engaged.

However, the TC2290 can also be added to an auxiliary bus, and one or more channels can send a portion of their signal to this bus to be processed by the effect. The output of the effect is then mixed back in with the rest of the tracks. This differs from an insert effect in that the TC2290 isn't affecting the track's entire signal, so the direct signal cannot be modulated using the MOD buttons in the PAN/DYN section. In this setup, the Mix parameter should always be set to 100%.

Mono/Stereo Operation

The TC2290 can be used both as a mono instance on mono tracks and a stereo instance on stereo tracks. Depending on the specific DAW, a mono in/stereo out may also be available.

In the case of a mono out instance, the output signal is made by outputting the left plug-in channel only. In this case, panning should not be used.

Demo Mode

If the plug-in is installed without a hardware unit connected, the plug-in will default to demo mode. In this state, sound is processed but no controls are available. Once a hardware unit is connected, all controls become available.

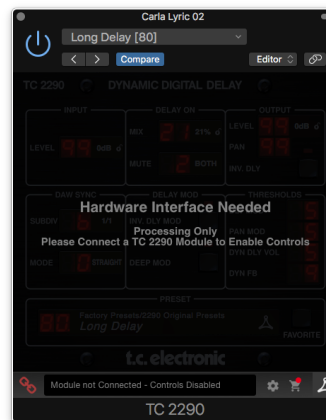

If the hardware unit is disconnected, automation and preset recall will still be available for 2 weeks, after which the plug-in goes into demo mode.

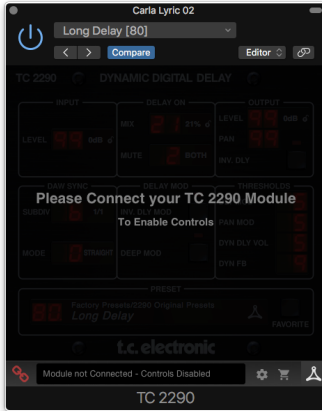

Connection Modes

After you have installed the plug-in and connected the TC2290 via USB, you can begin adding the effect to your tracks. Adjustments to the effect are done with 2 sets of parameters:

Primary – the parameters that are adjusted on the physical unit. These include common items such as delay time and feedback.



Secondary – the parameters adjusted in the plug-in UI window. The secondary parameters are the ones that were known as “SPEC KEYS” (Special Keys) on the original 2290. These parameters can be called from the hardware unit using the SPEC KEYS.



All of these parameters will be discussed in detail later in this manual.

Supported DAWs

The plug-in is available in these formats:

- VST2.4 (Ableton, Cubase, Nuendo, Reaper, Audition, most others)
- VST3 (Ableton, Cubase, Nuendo, Studio One)
- AU (Logic, Ableton)
- AAX (Pro Tools)

The following DAWs have been specifically tested to work with the TC2290 plug-in:

- Pro Tools
- Logic Pro
- Cubase
- Ableton Live
- Studio One
- Nuendo
- Reaper
- Reason
- Garage Band

However, the plug-in is not necessarily limited to the hosts on this list. Most modern DAWs can make use of at least one of the four formats provided. Visit the product page on tcelectronic.com to see the latest supported DAWs.

Connection Status

Connection status is indicated on the lower left side of the plug-in window. Successful connection is indicated with a green chain icon.

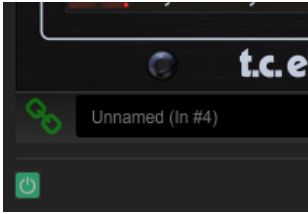

There are 3 conditions that will result in a “Not connected” status. If another instance of the plug-in already exists on another track, the chain icon will appear yellow with a yellow frame, and the text box will notify you where the plug-in is currently active. Click the chain icon to connect the hardware unit to the new plug-in location. The yellow icon may also appear while the connection is being made between the TC2290 unit and the plug-in, accompanied by “Connecting...” text.



If the hardware unit is disconnected from the computer, but the countdown has not yet expired, a yellow chain icon without the yellow frame will appear. See “Demo Mode” section for details.

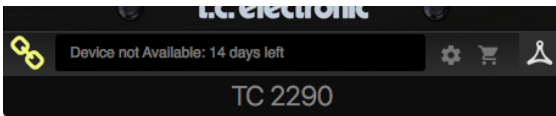

All other “Not connected” states are indicated by a red chain icon. This could happen if the USB cable is disconnected, the TC2290 connection is disrupted, or other issues.

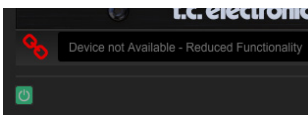

To summarize the connection status possibilities:



Most DAWs offer the ability to move or drag plug-ins from one track/bus to another, and TC2290 supports this as well.

Most DAWs also feature an on/off switch for plug-ins, accessible inside the plug-in window and/or the track itself. Muting the plug-in will make the effect inaudible, but will not shut down the connection to use the hardware unit.

4. Hardware and Plug-in Controls

Control of the TC2290 is divided between the hardware unit and the plug-in window. All commonly-used parameters of the 2290 are accessible through the hardware device. These include parameters that control major parts of the effect, such as delay time, modulation, preset changes, mix (via 'Special' control) and much more. Secondary parameters that are needed less often are handled in the plug-in window. These are parameters like modulation thresholds, subdivision, preset save and more.

4.1 Hardware Controls

Meters



The meter section gives feedback about the incoming and outgoing audio signals. The input level displays the audio as it enters the plug-in, and is not affected by adjustments to the input level control or any other parameter. The output meter is affected by the results of the effect as well as the output level control parameter.

MODULATION

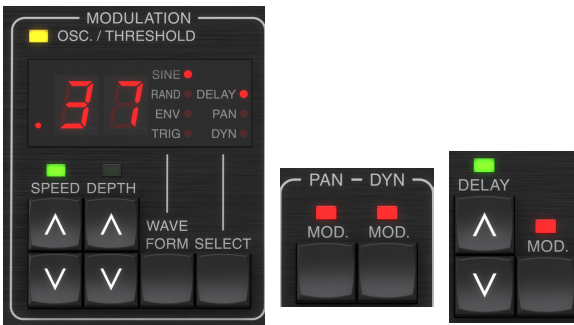

This section controls parameters of the modulation effects. Note that the modulation is actually engaged with the MOD buttons located in the PAN, DYN and DELAY sections.

Pressing the SELECT button scrolls through the parameter sets for the DELAY, PAN and DYNAMICS, essentially selecting the focus of the other buttons in this section. The types of modulation effects include:

- Delay time modulations – chorus, flanger, pitch, auto-doubling.
- Pan position modulations – auto-panning of the direct signal, delay signal, or both.
- Dynamic modulation – tremolo, delay compressor/expander, ducking and gating.

Each of these parameter sets consists of the following values:

WAVEFORM – determines the modulation waveform, between sine wave (SINE), random wave (RAND), input signal envelope controlled (ENV), or input level triggered (TRIG). The modulation target determines the function of ENV and TRIG.

SPEED – Pressing UP or DOWN once will bring focus to the SPEED parameter, and additional presses will move the value by one step. The SPEED parameter is shown in Hz (cycles per second). Depending on the modulation target, when the ENV or TRIG Waveform is selected, the parameter controls the speed from no effect to maximum effect. A setting of “1” means a ramp time of 1 second, whereas a setting of “5” means a ramp time of 1/5 of a second.

DEPTH – Pressing UP or DOWN once will bring focus to the DEPTH parameter, and additional presses will move the value by one step. The DEPTH value is displayed in percentage of maximum modulation.

Pressing the SPEED or DEPTH arrow keys will first bring focus to that parameter, which also allows a specific value to be entered on the KEYBOARD, followed by the ENTER key. When either parameter is active, a green LED will flash above and the display will show the current value.

The yellow OSC/THRESHOLD LED in the upper left corner of this section shows modulation speed when using periodic modulations (SINE, RANDOM) and indicates when the input level passes the threshold for ENV or TRIG effects.

PAN/DYN



Press either of the MOD buttons beneath the PAN and DYN labels to engage those functions respectively. The red LEDs above each button indicate the on/off status. The parameters for each effect are adjusted in the MODULATION section.

The DELAY/DIRECT button determines if the PAN effect is applied to the delay signal only, the direct signal only, both or neither. This also applies to the static pan set in the plug-in, so if neither DELAY nor DIRECT is lit, there is no panning at all.

When neither DELAY nor DIRECT is lit, the delay signal is phase inverted in the right channel. This is nice for creating wide chorus/flanger effects, but may not be desired for delay effects. To circumvent this, set PAN in the plug-in to 50, disengage PAN MOD, and enable PAN DELAY (not DIRECT). This will give the same result minus the phase inverse of right delay signal.

Note that whenever DIRECT is lit, the direct signal will first be summed to mono and then panned. When DIRECT is not lit, the direct signal will be stereo (if the plug-in is a stereo instance).

The REVERSE button causes the selected Dynamic effect to function in an opposite way. With the Waveform set to SINE or RAND, a tremolo effect is achieved which produces a modulated increase/decrease in volume. When the REVERSE button is activated, this creates a modulation that enhances delay volume when direct volume is suppressed and vice versa.

With the Waveform set to ENV or TRIG, the REVERSE button changes the usual Compression/Ducking effects into Expansion/Gating effects.

DELAY



The main function of this section is to control the delay time. The yellow LED above the display will flash in rhythm with the current tempo, and the exact time in ms will be displayed. There are several ways to adjust the delay time:

- Using the UP/DOWN arrows
- Using the KEYBOARD (after pressing UP/DOWN arrows once)
- Pressing the LEARN button in rhythm with your desired tempo
- Pressing the SYNC button to synchronize the tempo with the DAW tempo

A single press of the UP or DOWN arrow keys will bring focus to the delay tempo setting. Doing so causes the green LED to flash, and the tempo can now be adjusted. Pressing UP or DOWN will change the tempo by single digit increments, or holding the button will allow the parameter to scroll quickly.

However, once the green LED is flashing, the KEYBOARD can also be used to manually enter a delay time, followed by the ENTER key. If you use the KEYBOARD to enter the delay time, please note that you can enter values with decimals, including values below one millisecond by pressing the dot. For example, a delay time of 8.5 ms can be dialed by pressing [8] [dot] [5] [ENTER].

If you don't know the exact tempo measurement for your desired tempo, you can get fairly close by tapping the LEARN button in rhythm. The time between the first and second press will be used as the new tempo.

The TC2290 can also follow the tempo currently set in your DAW. Press the SYNC button to enable this. Once enabled, the UP and DOWN buttons will change the subdivision of the beat.

To enable modulation of the delay signal, press the MOD button. See the MODULATION section in this chapter as well as Chapter 5 for details.

FEEDBACK



This section primarily controls the number of delay repeats, but it also affects other functions.

Pressing the SELECT button scrolls through the 3 adjustable parameters in this section – feedback LEVEL, HIGH cut, and LOW cut filters. The display will indicate the current selection as well as the value for that parameter.

Pressing the UP or DOWN arrow buttons will activate the adjustment for the selected parameter, causing the green LED to flash. Further presses will change the value by one step, or holding the button will scroll rapidly. With the green LED flashing, an exact value can be entered on the KEYBOARD, followed by the ENTER button. The possible values for the 3 parameters are as follows:

- Feedback – 0-99%
- High cut – 2, 4, 8, 33 kHz (33 kHz = off)
- Low cut – 0, 0.1, 0.2, 0.4 kHz (0 = off, 0.1 = 100 Hz, etc.)

Pressing the INV button inverts the feedback signal, which may not be noticeable with echo effects, but is more pronounced when applied to modulation such as flanger.

PRESET/SPEC



Pressing the DELAY ON button toggles the delay effect on and off, indicated by the red LED. However, after turning this switch off, the direct signal is still heard along with any panning effects. Note that the static pan position (set by PAN in plug-in) is only used when DELAY ON is not lit when Spec key 26 (MUTE) is set to 0 (IN). Otherwise (Spec 26 non-zero), the direct pan position is center.

Pressing the UP or DOWN arrow once will engage the preset selection, allowing presets to be scrolled one-by-one, or a specific preset can be entered on the KEYBOARD, followed by the ENTER button. See Chapter 6 for details.

The SPEC (Special) button allows control of some parameters that are otherwise only accessible in the plug-in window. Pressing the SPEC button accesses the Special Number (SNO) and the Special Value (SVA). The Special Number can only be entered on the KEYBOARD, followed by the ENTER button, whereas the Special Value can be entered with the KEYBOARD or preset arrow keys. The following chart shows the available parameters that can be controlled:

Special Number	Parameter	Possible Values
1	Input Level	0-99 (off – 0 dB)
2	Delay Mix (default)	0-99%
3	Output Level	0-99 (off – 0 dB)
4	Pan	0-99
5	Invert Delay	0 (off), 1 (on)
6	DAW Sync Subdivision	0-6 (64th note – whole note)
7	DAW Sync Mode	0 (straight), 1 (dotted), 2 (triplet)
8	Delay Deep Mod	0 (off), 1 (on)
9	Invert Delay Mod	0 (off), 1 (on)
10	Delay Mod Threshold	1-9
11	Pan Mod Threshold	1-9
12	Dynamic Delay Volume	0-8
13	Dynamic Feedback	0-8
26	Mute Method	0 (In), 1 (Out), 2 (Both)

EN

Knowing that DELAY MIX will likely be the most common plug-in parameter that users will need to access regularly, this has been programmed as the default Special Number. As soon as the SPEC button is pressed, Special #2 (DELAY MIX) will appear as the SNO entry, and the SPEC button can be pressed again to toggle focus to the DELAY MIX value (SVA). Use the arrow keys or KEYBOARD to enter the desired value. Press SPEC again to return to the normal preset select state.



To access a Special number other than DELAY MIX, press the SPEC button until SNO is highlighted with a red LED. Dial the desired Special Number on the KEYBOARD and press ENTER, which will automatically toggle the SPEC focus to Special Value (SVA). Dial the value using the UP/DOWN arrows or the KEYBOARD.

KEYBOARD



The KEYBOARD section is used to enter specific values or presets instead of scrolling with arrow buttons. Generally, when entering a specific value, the green LED associated with that parameter section must be flashing in order for the KEYBOARD to take effect. After a value has been chosen, press the ENTER button to confirm.

4.2 Plug-in Controls

INPUT



Click and drag up or down to adjust the input level from 0 to 99. Alternatively, double click on the numeral to enter a value manually. A setting of 0 is $-\infty$, and a setting of 1 is -96 dB. The level increases in 3 dB increments at lower settings, and by 0.5 dB increments above -40 dB.

DELAY ON



Click and drag the MIX parameter to adjust the balance between the direct and delay signals.

Click the right side of the MUTE mode parameter to select whether muting affects the input or output signals, or both. Muting the input will allow the echo tail to fade naturally after the effect is bypassed.

OUTPUT



Click and drag up or down to adjust the output level from 0 to 99. A setting of 0 is $-\infty$, and a setting of 1 is -96 dB. The level increases in 3 dB increments at lower settings, and by 0.5 dB increments above -40 dB.

Adjust the pan position of the signal by clicking and dragging the PAN parameter. Panning is only applied to signals chosen with the DELAY/DIRECT button in the PAN section of the hardware unit. With a setting of 50, both the direct and delay signals are centered. A setting of 0 places the direct signal hard right and delay hard left. A setting of 99 places the direct signal hard left and the delay signal hard right.

When the INV DLY button is activated, the output of the delay signal is phase inverted.

Lock Symbol

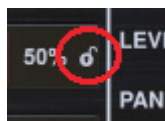

Some of the parameters can be locked from being recalled when a new preset is selected. Locked parameters will always keep their values no matter which preset you recall.

A great example of use is using it with the MIX parameter.

The default presets provided in the plug-in are typically created with the intent that the effect will be inserted on the track (as an insert effects). A MIX value has been chosen that will work for that preset.

However, if you'd like to use the TC2290 as a send/parallel effect, the MIX parameter should typically be set to 100%. After setting the MIX to 100%, use the lock function to make sure it stays at 100% even if you load another preset.

DAW SYNC



When the DAW SYNC selection is active (by pressing the SYNC button on the unit), some parameters can be adjusted to control the relationship between the delay and the DAW tempo.

The delay subdivision (SUBDIV) can be set anywhere from 1/64th note to a whole note. Note that this can also be adjusted using the arrow buttons in the DELAY section on the unit.

The subdivision can also be heard in straight time, dotted, or triplet feel by adjusting the MODE setting.

DELAY MOD



When engaged, the INV DLY MOD button inverts the flanger sweep start and the envelope pitchshift direction. This only applies to Delay Mod Waveforms ENV and TRIG.

Engage the DEEP MOD by pressing the button. DEEP MOD disables the automatic modulation depth mapping known as “Golden Ratio”. This makes it possible to do much deeper modulation with wild pitch shifts, but it is somewhat uncontrollable.

THRESHOLDS



All 4 of these items offer 9 threshold settings for their respective parameter. Range for each parameter is 1-9.

DLY MOD – Delay ENV and TRIG waveforms.

PAN MOD – Pan ENV and TRIG waveforms.

DYN DLY VOL – Determines the threshold for the volume modulation of the delay (and direct for ENV REVERSE) signal when DYN modulation is ENV or TRIG.

DYN FB – Determines the threshold for the modulation of the feedback level when DYN modulation waveform TRIG is selected (not ENV).

These set the thresholds associated with the Envelope (ENV) and Trigger (TRIG) modulation forms. The higher the value, the higher input signal is necessary to get the same modulation effect. Delay, Pan and Dynamic thresholds are adjustable in 3 dB steps. The OSC./THRESHOLD LED indicates the current operating state, and can therefore be used as help for setting the threshold.

PRESET



Use the PRESET section to recall and save presets as well as assigning them as favorites. See Chapter 6 for details.

Bottom section

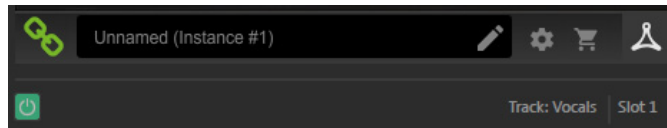

The bottom portion of the plug-in window displays connection status as well as plug-in instance name, and has several options available.

The green chain icon indicates successful connection between the hardware unit and the plug-in. Connection issues will be indicated by yellow or red icons; see Chapter 3 for details.

The current name of the plug-in instance appears in the middle field. If the DAW is able to provide the name of the track where the plug-in instance is inserted, the plug-in instance will be named after the track name. The instance can be renamed by clicking the pencil icon.

If you install the plug-in without connecting the hardware unit to your computer, a red dot will appear on the shopping cart icon. This will link you to more information about buying the TC2290 unit. Once the plug-in detects a connected hardware unit, the red dot will disappear.

The Settings icon accesses a menu with several links and options. This user manual is available, along with links to the TC Electronic website, relevant news, additional signature artist presets, and the user license agreement. If a red dot appears over the Settings icon, a new version of the plug-in or firmware may be available. Click “Check for Updates” to download and install the new file. See Chapter 7 for details.

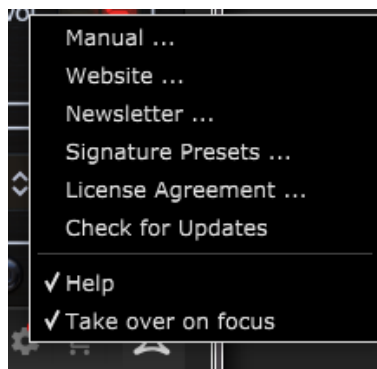

With the “Help” option selected, hovering the mouse over a certain item in the plug-in window will give a brief description of the parameter’s function and the Special key number (if applicable).

With the “Take over on focus” option selected, the currently viewed plug-in instance will take over control of the physical hardware unit as soon as it is brought into focus.

Also, when a new instance of the plug-in is inserted on a track or bus, that instance will take over immediately.

5. Operation

This chapter will discuss the details of creating certain effects and how to adjust each parameter. After you have connected the hardware unit to your computer and have the plug-in inserted in a channel or bus, you are now ready to start experimenting with the capabilities of the TC2290. The default presets and signature presets may be a good place to start to get an idea of what is possible. In the plug-in window, click the current preset name, then navigate to 'Original 2290 Presets' or 'Signature Presets'. You either need to send live audio to the plug-in, or apply the effect to a prerecorded track.

On the hardware unit, in the PRESET/SPEC section, make sure the DELAY ON button is active (LED lit). Most of the significant effect parameters are accessed on the hardware unit, so we'll focus attention there.

5.1 Delay Parameters

The TC2290 is, first and foremost, a delay unit, so we can start with the 3 main parameters:

- Delay time – This controls the rate of the echoes.
- Feedback – This controls how many echoes are heard.
- Mix – This adjusts the volume balance between the delay echoes and the direct signal.

Delay Time

If you select a default preset that uses delay (#80 for example), you'll see that the yellow TIME LED above the DELAY display will flash in rhythm with the current tempo, and the exact time in ms will be displayed.

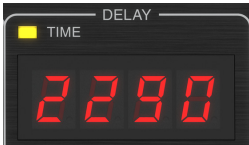

There are several ways to adjust the delay time:

- Using the UP/DOWN arrows
- Using the KEYBOARD (after pressing UP/DOWN arrows once)
- Pressing the LEARN button in rhythm with your desired tempo
- Pressing the SYNC button to synchronize the tempo with the current DAW tempo

A single press of the UP or DOWN arrow keys will bring focus to the delay tempo setting. Doing so causes the green LED to flash, indicating that the tempo can now be adjusted manually.



Pressing UP or DOWN will change the tempo by single digit increments, or holding the button will allow the parameter to scroll quickly. However, once the green LED is flashing, the KEYBOARD number pad can also be used to manually enter a delay time, followed by the ENTER key.



If you don't know the exact tempo measurement for your desired tempo, you can get fairly close by tapping the LEARN button in rhythm. The time between the first and second press will be used as the new tempo. You can see on the display that the first press causes the numbers to start from 0 and ascend very quickly (these are milliseconds after all). If you do this several times, you may notice that you get a slightly different result each time, so the tempo may still need to be tweaked manually using the arrow buttons.

The TC2290 can also follow the tempo currently set in your DAW. Press the SYNC button to enable this. Let's say your DAW tempo is set to 120 BPM, which tends to be the default setting in a new project/session.



Press the SYNC button, and the TC2290 will convert the tempo into ms, which is 250.

Once SYNC is enabled, the UP and DOWN buttons will change the subdivision of the beat. The subdivision is currently set to eighth notes in the DAW SYNC section of the plug-in window, which gives us 250 ms at 120 BPM.



This can be changed to quarter notes by pressing the UP button in the DELAY section of the hardware unit, or making the change in the DAW SYNC section of the plug-in window. Making a change to one will cause the other to be altered as well. Change the subdivision to quarter notes, and you now have a delay time of 500 ms.

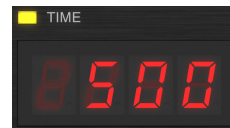

Even with DAW SYNC enabled, the LEARN button can still be used to set the tempo. When this is done, the TC2290 will grid to the nearest subdivision and mode (Straight, Dotted, Tripled) within the DAW-synced tempo, and set the delay time accordingly.

FEEDBACK

Feedback controls the number of echoes that are created by the effect.



Press the SELECT button until the LED next to LEVEL is lit. This ensures that we are adjusting the feedback parameter and not the high or low cut filters.

Pressing the UP or DOWN arrow buttons causes the green LED in this section to flash. We can now adjust the feedback parameter, either by pressing or holding the UP/DOWN buttons, or by entering a value with the KEYBOARD followed by the ENTER key.

MIX

The last parameter to adjust a basic delay setting is the MIX between the echoes and the direct signal. To access this parameter, press SPEC twice and use the UP/DOWN arrows to set the MIX.



Alternatively, the MIX setting can be adjusted using the plug-in UI.

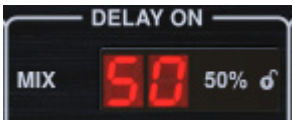

If using the plug-in as an insert on a channel, you will likely want a setting below 50% to avoid a muddy-sounding result. However, if using the plug-in as a send/aux effect, set the MIX to 100%.

5.2 Modulation Effects

The TC2290 has 3 kinds of modulation effects available:

- Delay Time modulations – chorus, flanger, pitch modulation, auto-doubling effects.
- Dynamic modulations – tremolo, compress/expand, ducking/gating effects.
- Pan position modulations – auto-panning effects.

Each of these effects has its own MOD on/off button.



The parameters for each of these modulations are controlled in the MODULATION section on the hardware unit. By using the SELECT button within this section, you can scroll through the 3 types of modulation.



After the modulation type has been selected, the 3 parameters in this section can be adjusted, which are:

WAVEFORM – determines the modulation waveform, between sine wave (SINE), random wave (RAND), input signal envelope controlled (ENV), or input level triggered (TRIG). The modulation target determines the function of ENV and TRIG.

SPEED – Pressing UP or DOWN once will bring focus to the SPEED parameter, and additional presses will move the value by one step. The SPEED parameter is shown in Hz (cycles per second).

Depending on the modulation target, when the ENV or TRIG Waveform is selected, the SPEED parameter controls the rate of change from no effect to maximum effect. A setting of “1” means a ramp time of 1 second, whereas a setting of “5” means a ramp time of 1/5 of a second.

DEPTH – Pressing UP or DOWN once will bring focus to the DEPTH parameter, and additional presses will move the value by one step. The DEPTH value is displayed in percentage of maximum modulation.

Pressing the SPEED or DEPTH arrow keys will first bring focus to that parameter, causing a green LED to flash above and the display to show the current value. This means the arrow buttons can change the value by single steps, and also allows a specific value to be entered on the KEYBOARD, followed by the ENTER key.

Note- the feedback parameter of the delay may also have an effect on modulation effects.

Each of these parameters affects the sound differently depending on the specific effect. Let’s review each type of modulation and how it can be adjusted.

5.2.1 Dynamic Effects

In the MODULATION section, use the SELECT button to highlight the Dynamics (DYN) parameters. Ensure that the MOD button is engaged in the center PAN/DYN section.

Ducking Delay

A ducking delay uses the input signal to attenuate the delay signal, causing the echoes to stay “out of the way” while you’re playing, but still allow the echo tails to be audible during gaps in your playing.

Press the WAVEFORM button until TRIG is selected. This selects the ducking effect.

Press the DEPTH UP or DOWN button to shift focus to this parameter. The green LED will flash above and the current value is displayed. This parameter controls how much the delay signal is attenuated. Lower the value for small amounts of attenuation, or raise it to make the effect almost inaudible while you’re playing.

Press the SPEED UP or DOWN button to shift focus to this parameter. This controls the rate at which the attenuation is released. Lower values allow a longer period of time to pass after you stop playing before the echoes increase to their normal volume. Higher values let the echoes come in quickly.

Gated Delay

By pressing the REVERSE button in the PAN/DYN section, the ducking effect becomes a gated delay. Set this way, the effect will only be heard while you are playing, and will be attenuated when you stop.



Tremolo Effect

Press the WAVEFORM button until SINE or RAND are selected. This creates a tremolo effect where the volume of both the direct and delay signals are attenuated and then return to full volume, up and down at a constant rate (SINE only). Use the SPEED parameter to adjust the specific rate, and the DEPTH to adjust the amount of attenuation.

By engaging the REVERSE button, the direct signal and delay signal are attenuated opposite one another, with the direct reaching full volume while the delay is at maximum attenuation, and vice versa.

Compressor/Expander Effect

Press the WAVEFORM button until ENV is selected. This produces a compressed delay sound similar to the ducking effect, but less pronounced and leaves the feedback unaffected.

Engaging the REVERSE button produces an expander effect that affects the direct and delay signals. Initial transients are attenuated, creating an 'attack-kill' effect. The SPEED parameter controls how quickly the volume swells to normal level, and the DEPTH parameter controls the amount of initial attenuation.

5.2.2 Chorus/Flanger/Doubling Effects

In the MODULATION section, use the SELECT button to highlight the DELAY parameters. Ensure that the MOD button is engaged in the DELAY section.

Several types of modulation can be achieved by setting very short delay times, which are not heard as an echo, but rather as an extra, synchronized voice. Some common delay and feedback levels are outlined here:

Delay Time	Effect	MOD button	Feedback Setting	Mix
0-10	Flanger	ON	Very High	50
5-50	Chorus	ON	Slight or none	50
20-80	Double Track	ON	Slight or none	50
100-up	Delayed Chorus	ON	Set for repeats	50

Chorus

Chorus effect is achieved by mixing the direct signal with a modulated delay signal. The result is a multi-voice character that sounds like more than one instrument playing in unison, with small variations in pitch and time.

In the DELAY section, set the time very low – around 20-25 ms. In the FEEDBACK section, reduce the level all the way to 0.

Press the WAVEFORM button to select SINE, which is very common for Chorus effects. Other waveforms will be discussed later in this chapter.

In the MODULATION section, ensure that DELAY is selected, and adjust the DEPTH parameter to control the intensity of the effect. Higher values create a deeper detune. Adjust the SPEED parameter to control the rate of the modulations.

Note that setting the MIX control to 99 produces a pure vibrato effect, where the pitch is modulated up and down without the direct signal to create the 2 voices.

Flanger

Flanger effects produce sweeping wave-like modulations that create a thick, often psychedelic sound. This will operate similarly to the chorus effect, with a few adjustments.

In the FEEDBACK section, raise the feedback level parameter to 50. The higher the feedback setting, the more resonant the flanger effect will be. Settings below 90 are recommended.

For classic jet flanger effects, set the DELAY time around 2 ms.

In the MODULATION section, try setting the SPEED parameter very low to make the sweeps slower. Increasing the DEPTH parameter produces wider sweeps.

Other Waveforms

Though the SINE option will give you recognizable chorus and flanger sounds, there are other effects achievable with different waveforms. The RAND setting will yield a random sweep instead of the continuous form of the SINE.

The ENV setting produces a ramp that starts and stops with the input level. Higher SPEED settings and moderate DEPTH settings might be necessary.

Selecting TRIG creates a sine sweep that stops whenever the input signal stops. This allows the sweep to be synchronized along with the music.

Auto Doubling

This effect is a specific type of chorus that gives the impression of 2 identical players/singers performing the same part in unison. Try low DELAY times around 20-80 ms, low FEEDBACK setting, slight pitch shift, slight volume modulation, and changes in panning position. This effect requires all 3 MOD buttons to be active.

Default presets 95 and 97 are good examples of this effect, so starting with those settings would be wise.

5.2.3 Panning Effects

In the MODULATION section, use the SELECT button to highlight the PAN parameters. Ensure that the MOD button is engaged in the center PAN/DYN section.

The panning effect can be applied to the direct signal, the delay signal, both or neither. This is selected using the DELAY/DIRECT button in the PAN/DYN section. Pressing repeatedly toggles through the 4 possible settings. One of the LEDs must be lit in order for any panning effects to be heard.



The fixed pan position can be adjusted in the plug-in window using the PAN control in the OUTPUT section. When DELAY/DIRECT is selected, a setting of 50 is centered, 0 is far right, and 99 is far left for the direct signal, and the delay signal will be the opposite.



Pressing the PAN MOD button, you will hear audio traveling from one speaker to the other, depending on the setting on the DELAY/DIRECT button.

In the MODULATION section, select the SINE waveform, then use the SPEED parameter to adjust how quickly the audio is panned back and forth.

The DEPTH parameter adjusts how wide the panning effect drifts from left to right and back. A setting of 99 will pan fully to either side, while a setting of 50 only goes half way before changing direction again.

Selecting the ENV waveform causes the static pan position to switch each time the signal falls below the threshold. If both the DELAY and DIRECT signals are selected for the effect, they trade sides. Fairly fast SPEED settings and high DEPTH setting are more effective for this sound.

The TC2290 can be used as an autopanner on the direct signal only by setting the MIX control in the plug-in window to 0.

6. Presets

The TC2290 offers a collection of default and signature presets, as well as the option to create and save your own custom settings.

Note that most DAWs have a built-in preset function that appears on every plug-in, which is often found at the top of the plug-in window.

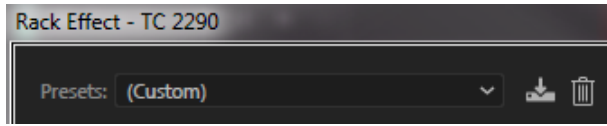

It is not recommended to use this as your primary method of saving presets as it has limited functionality and does not allow the saved presets to be transferred easily to other DAWs. Instead, we suggest using the included Preset section at the bottom of the window:



A single click on the PRESET window brings up a menu with several preset-related options. Recall a factory or user preset from the libraries, save the current preset, or create a new user preset with the 'Save as' option.

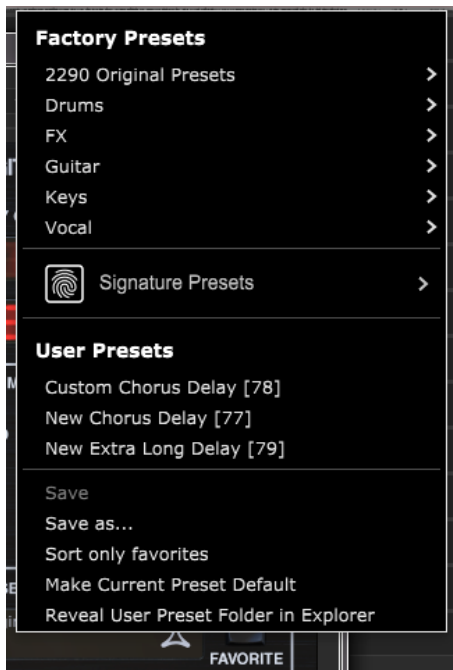

The presets menu is divided between a Factory Presets and a User Presets section.

The Factory Presets are built into the plug-in and cannot be overwritten, so if a factory preset is modified and you'd like to keep the changes, you need to save it as a user preset. User Presets can be edited and organized as you'd like.

The Factory Presets section includes a sub-section called Signature Presets. Signature Presets are custom-made presets designed by world-class artists and recording engineers. The library of signature presets is constantly being expanded, and you can check for more Signature Presets that might be available for download by accessing the Settings menu and selecting 'Signature Presets'.

Factory and Signature presets have unique icons that appear next to the preset name.



When recalling a default or saved preset, the name will appear in plain text as shown. However, as soon as you make an alteration to any of the parameters in that preset, the text changes to italics to indicate a deviation. This is also indicated by a red dot after the preset number on the hardware unit and in the plug-in window. You can click in the PRESET window, then select the Save option, or discard the changes when you navigate away from that preset.



Presets can also be recalled from the hardware unit in the PRESET/SPEC section.



Pressing the preset UP or DOWN arrow buttons shifts the focus to that section, causing the green LED to flash. You can now press the UP and DOWN buttons to scroll through presets one slot at a time, or use the KEYBOARD to enter a specific preset number, followed by the ENTER button.

Favorite Preset

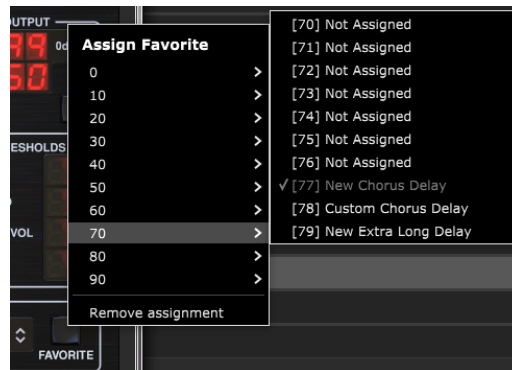

Creating your own presets will make them accessible from the Preset menu, but they will only appear in the list of 100 presets in the hardware unit if you set them as a favorite. This is done by assigning a favorite slot number to the preset using the Favorite menu. Click the FAVORITE button, then select one of the first 8 banks of 10 (presets 80-100 are default and cannot be saved over). Assign one of your custom presets to a favorite slot, then save the preset.

When a preset is assigned a favorite slot number:

- The preset is part of the 100 presets that can be recalled on the hardware unit
- The favorite number will be displayed on the hardware unit when recalled
- The favorite number will be locked so that other presets can not be assigned to the same favorite slot number. This is shown in the Favorite menu by graying out the number in question.
- The favorite number will be displayed in brackets when you browse the presets menu

User Presets

Custom Chorus Delay [78]

You can remove the favorite assignment by selecting the "Remove Assignment" feature in the Favorite menu, then saving the preset.

Sort only favorites

The 'Sort only favorites' option in the preset menu allows the UP/DOWN arrows on the hardware unit to scroll only through the favorites list. Otherwise, scrolling goes through all presets.

Make Current Preset Default

Selecting 'Make current preset default' will cause this preset to appear every time a new instance of the plug-in is created.

Reveal User Preset Folder in Explorer

To change the name of a preset, select 'Reveal User Preset Folder in Explorer' and modify the file name. This will open a Finder (Mac) or Explorer (PC) window where the user presets are stored. You can rename as well as delete, copy and paste presets. This allows you to share presets with other users online, simply pasting the new ones in this folder.

7. Hardware Unit Software Updates

New versions of the software may be released to add new features and improve performance. Updates can be detected from the plug-in directly and can be installed after download from the website. See Chapter 2 for plug-in installation.

The hardware unit firmware will be included in each plug-in update. After you have installed a new plug-in, the system will detect mismatched firmware and indicate a need for update via a small red dot on the gear icon.

If the 'Automatically check for updates' option is checked inside the update menu, the red dot will appear on the settings icon when a new plug-in is available.

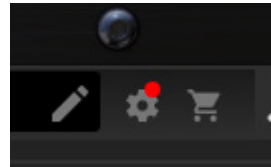

Click the gear icon and select "Check for Updates" to perform a scan.

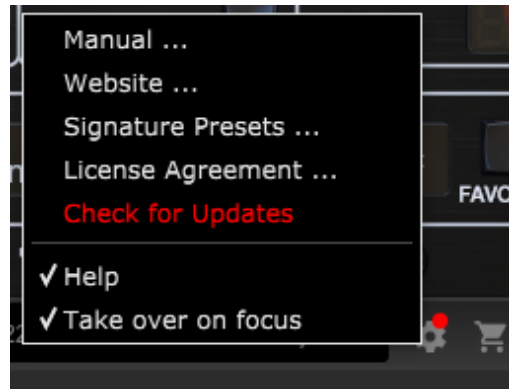

Click the "Upgrade to x.x.xx" field to start the update. Progress will be indicated in the plug-in, and the Feedback LED on the hardware unit will flash.

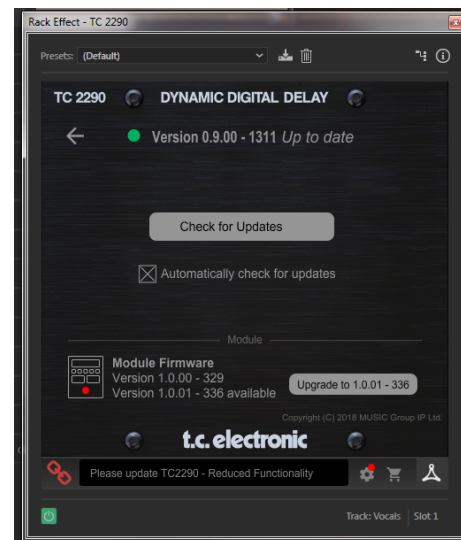

8. Specifications

Global

Type	USB 2.0, type micro-B
------	-----------------------

Power

Power supply	USB bus powered
--------------	-----------------

Power consumption	Max. 2.5 W
-------------------	------------

Software Support

Operating systems	Mac OS X 10.10 Yosemite or above (32/64 bit) Windows 7 or above (32/64 bit)
-------------------	--

Drivers	No additional drivers required, uses standard USB HID drivers
---------	---

Supported sample rates	44.1, 48, 88.2, 96, 176.4, 192 kHz
------------------------	------------------------------------

Supported formats	VST2.4, VST3, AU, AAX
-------------------	-----------------------

Physical

Dimensions (HxWxD)	43 x 109 x 135 mm (1.7 x 4.3 x 5.3")
--------------------	--------------------------------------

Weight	0.4 kg (0.88 lbs)
--------	-------------------

EN 9. Signal Flow Diagram

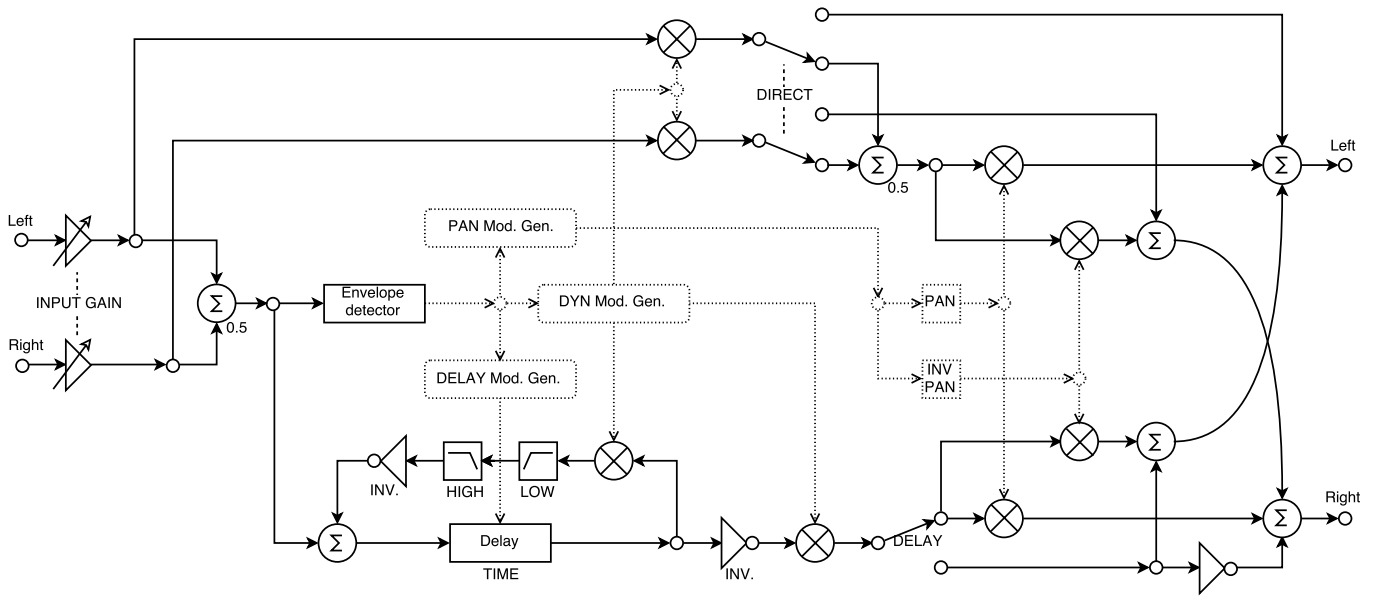

DELAY Mod. Control

INPUT:
DELAY ON

MODULATION:
SPEED
DEPTH
WAVEFORM

DELAY:
MOD.

SPEC:
9 - INV DLY MOD
10 - DLY MOD Threshold
8 - DEEP MOD

PAN Mod. Control

INPUT:
DELAY ON

OUTPUT VOLUMES:
PAN

MODULATION:
SPEED
DEPTH
WAVEFORM

PAN:
MOD.

SPEC:
11 - PAN MOD Threshold

DYN Mod. Control

INPUT:
DELAY ON

MODULATION:
SPEED
DEPTH
WAVEFORM

DYN:
MOD.
REVERSE

SPEC:
12 - DYN DLY VOL
13 - DYN FB

FEDERAL COMMUNICATIONS COMMISSION COMPLIANCE INFORMATION



Responsible Party Name: **MUSIC Tribe Commercial NV Inc.**
Address: **5270 Procyon Street,
Las Vegas, NV89118.**
Phone Number: **+1 702 800 8290**

TC2290-DT

complies with the FCC rules as mentioned in the following paragraph:

This equipment has been tested and found to comply with the limits for a Class B digital device, pursuant to part 15 of the FCC Rules. These limits are designed to provide reasonable protection against harmful interference in a residential installation. This equipment generates, uses and can radiate radio frequency energy and, if not installed and used in accordance with the instructions, may cause harmful interference to radio communications. However, there is no guarantee that interference will not occur in a particular installation. If this equipment does cause harmful interference to radio or television reception, which can be determined by turning the equipment off and on, the user is encouraged to try to correct the interference by one or more of the following measures:

- Reorient or relocate the receiving antenna.
- Increase the separation between the equipment and receiver.
- Connect the equipment into an outlet on a circuit different from that to which the receiver is connected.
- Consult the dealer or an experienced radio/TV technician for help.

This equipment complies with Part 15 of the FCC Rules. Operation is subject to the following two conditions:

- (1) This device may not cause harmful interference, and
- (2) This device must accept any interference received, including interference that may cause undesired operation.

Important information:

Changes or modifications to the equipment not expressly approved by Music Tribe can void the user's authority to use the equipment.

