



RETROCAST

USB MICROPHONE WITH VINTAGE STYLING

Retrocast

USB Microphone With Vintage Styling

Retrocast is the perfect way to combine the look and feel of classic radio broadcasting with a modern, high-performance microphone that's perfect for podcasts and DAW recording.

At the heart of Retrocast is a 22mm dynamic element with a directional cardioid polar pattern. The result? A wide ranging frequency response (40 – 16,000Hz), high sensitivity (-52dB ± 3dB (0dB = 1V/Pa @ 1kHz)) and fast transient response that combine for premium capture and faithful recreation of every subtle nuance of a sung or narrated vocal part - all with minimal interference from unwanted ambient noise.

With Retrocast, complicated setups are a thing of the past. The built-in driver facilitates rapid plug-and-play USB performance on both Mac and PC operating systems. For professional capture every time, the Retrocast boasts studio-grade A/D conversion at 96kHz / 32-bit for a recording resolution with uncompromised dynamic range and

frequency response. When combined with an equally vintage styled desktop tripod stand for optimum microphone placement, pristine audio capture is guaranteed every time.

Features

- Vintage styling evokes feel of classic radio broadcasting
- Cardioid pickup pattern is ideal for desktop recording
- USB output is perfect for podcasting and DAW recording
- Wide-range 40-16kHz frequency response ensures high-quality sound
- Complete with cable and mini tripod stand

Box Contents

- Retrocast Microphone
- USB Cable
- 3/8" Stand Adapter
- Mini Tripod Stand
- User Guide

Polar Pattern

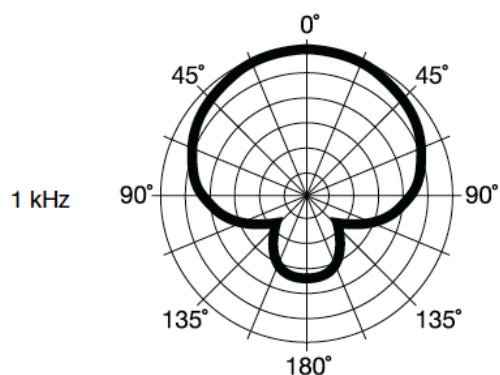

Frequency Response

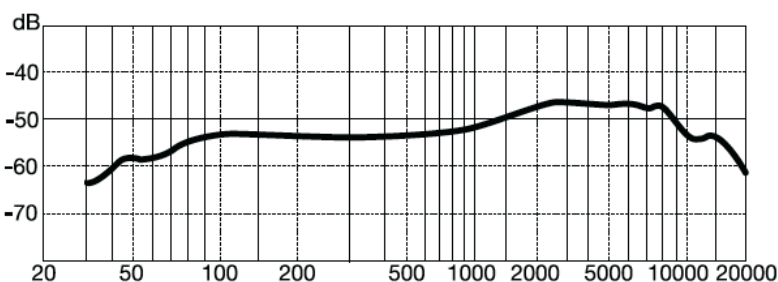

Technical Specifications

Type	Dynamic USB microphone
Polar Pattern	Cardioid
Frequency Response	40–16000 Hz
Sensitivity	-52 dB +3 dB (0 dB = 1 V/Pa @ 1 kHz)
Impedance	Output: 250 Ω +30% (@ 1 kHz)
Power	USB
Dimensions (length x diameter)	Microphone: 7.48" x 2.68" / 190 x 68 mm. Microphone + stand: 14.17" x 7.50" / 360 x 191 mm
Weight	Microphone: 1.14 lbs. / 0.51 kg. Stand: 1.14 lbs. / 0.51 kg

User Summary & Target Demographics

The primary target market for the Marantz Professional Retrocast is musicians, vloggers and podcasters seeking a cost-effective means to capture professional quality recordings via USB to Mac and PC operating systems. Combining

a wide ranging frequency response, high sensitivity specification and studio grade, high-resolution A/D conversion, Retrocast provides core plug-and-play audio capture without the need for a separate audio interface.