

MESA/BOOGIE
THE HOME OF TONE.®



Owner's Manual

Greetings from the Home of Tone®

...You, smart player and intuitive human, have put your trust in us to be your amplifier company. This is something we do not take lightly. By choosing this instrument to be a part of your musical voice, you have become part of the Mesa family... WELCOME!

Our goal is to never let you down. Your reward is that you are the new owner of an amp, bred of fine all tube heritage...benefiting from the many pioneering and patented Mesa circuits that led to the refinement of your new model. We feel confident this amp will inspire many hours of musical satisfaction and lasting enjoyment. It was built with you in mind by players who know the value of a fine musical instrument and the commitment it takes to make great music. The same commitment to quality, value and support we make to you...our new friend.

BASS PRODIGY™

TABLE OF CONTENTS

Precautions	
Overview	1-3
Helpful Hints	4

FRONT PANEL:

INSTRUMENT INPUT	5
INPUT SELECT SWITCH	5
CONTROLS:	
GAIN, BASS	6
MID	6-7
TREBLE	7
VOICE	7-8
MASTER	8
MUTE / PLAY / SILENT RECORD SWITCH	8
FULL / HALF POWER SWITCH	9
PRE / POST: D.I. OUTPUT SELECT SWITCH	9-10
D.I. LIFT / GROUND, D.I. LEVEL	10
SOLO CONTROL	10
POWER SWITCH	11
STANDBY SWITCH	11

REAR PANEL:

AC MAINS FUSE, FUSE RATING AND REPLACEMENT	13
POWER CABLE, EXTERNAL SWITCHING	14
SEND / RETURN	14-15
TUNER	15
SLAVE	15
FOOTSWITCH JACK	16
SPEAKER OUTPUTS	16-17
D.I. OUTPUT	18
FACTORY SAMPLE SETTINGS	19
PERSONAL SETTINGS	20
BIASING THE KT-88 POWER TUBES	21-22
SPEAKER IMPEDANCE MATCHING AND HOOKUP GUIDE	23-28
TUBE NOISE AND MICROPHONICS	29-30
TUBE REPLACEMENT CHART	32
PARTS SHEET	33

Important Safety Instructions

Read these instructions.

Keep these instructions.

Heed all warnings.

Follow all instructions.

Do not use this apparatus near water.

Clean only with dry cloth.

Do not block any ventilation openings. Install in accordance with the manufacturer's instructions.

Do not install near any heat sources such as radiators, heat registers, stoves, or other apparatus (including amplifiers) that produce heat.

Do not defeat the safety purpose of the polarized or grounding-type plug. A polarized plug has two blades with one wider than the other. A grounding type plug has two blades and a third grounding prong. The wide blade or the third prong are provided for your safety. If the provided plug does not fit into your outlet, consult an electrician for replacement of the obsolete outlet.

Protect the power cord from being walked on or pinched, particularly at plugs, convenience receptacles, and the point where they exit from the apparatus.

Only use attachments/accessories specified by the manufacturer.

Unplug this apparatus during lightning storms or when unused for long periods of time.

Refer all servicing to qualified service personnel. Servicing is required when the apparatus has been damaged in any way, such as power-supply cord or plug is damaged, liquid has been spilled or objects have fallen into the apparatus, the apparatus has been exposed to rain or moisture, does not operate normally, or has been dropped.

To insure proper ventilation always make sure there is at minimum four inches (101.6mm) of space behind the rear of the apparatus. The ventilation should not be impeded by covering the ventilation openings with items, such as newspapers, tablecloths, curtains, etc. Do not impede ventilation by placing objects on top of the apparatus which extend past the rear edge of its cabinet.

No naked flame sources, such as lighted candles, should be placed on the apparatus.

The apparatus shall not be exposed to dripping or splashing and no objects filled with liquids, such as vases, shall be placed on the apparatus.

READ AND FOLLOW INSTRUCTIONS OF PROPER USAGE

Important Safety Instructions

WARNING: To reduce the risk of fire or electric shock, do not expose this apparatus to rain or moisture.

The AC plug is the mains disconnect. The plug should remain accessible after installation.

WARNING: EU: permission from the Supply Authority is needed before connection.

WARNING: Always make sure proper load is connected before operating the amplifier. Failure to do so could pose a shock hazard and may result in damage to the amplifier.

Do not expose amplifier to direct sunlight or extremely high temperatures.

Always insure the amplifier is properly grounded. Always unplug AC power cord before changing fuse, tubes or removing chassis. Use only same type and rating when replacing fuse.

Avoid direct contact with heated tubes. Keep amplifier away from children.

To avoid damaging your speakers and other playback equipment, turn off the power of all related equipment before making the connections.

Do not use excessive force when handling buttons, switches and controls. Do not use solvents such as benzene or paint thinner to clean the unit.

Always connect to an AC power supply that meets the power supply specifications listed on the rear of the unit. Export models: always insure unit is wired for proper voltage. Make certain grounding conforms with local standards.

Your amplifier is LOUD! Exposure to high sound volumes may cause permanent hearing damage!

When Rack Mounting this unit proper ventilation space must be maintained. Do Not cover or block Front and Rear and allow at least 2" of open "breathing" space on both sides of the unit. Allow 2 Rack Units of open space above the unit to allow heat to escape the upper rear vents.

NOTE: IMPORTANT – Do Not flip the STANDBY SWITCH in and out of STANDBY mode (on and off) while the amplifier is being played or with any type of signal being amplified. The large amount of current involved in this scenario can damage the STANDBY SWITCH.

Your Mesa/Boogie® Amplifier is a professional instrument. Please treat it with respect and operate it properly.

READ AND FOLLOW INSTRUCTIONS OF PROPER USAGE

BASS PRODIGY™

Operating Instructions

Congratulations on your choice of the BASS PRODIGY Four:88 and welcome to the **MESA/Boogie® Family!** First, we would like to thank you for choosing us as your amplifier company and trusting us to help create your musical voice. This is something we never take for granted and you'll find that we are here and ready to assist you should you ever need help. Our goal is to help you sound your best at all times! We feel confident that your new amplifier will bring you many years of reliable service, rewarding inspiration and create for you a newfound freedom to express your music.

You have chosen an amplifier bred of a fine all-tube heritage and this model is our testament to Tube Bass Tone. Its forefathers can be traced back to the very first MESA amplifier ever built, the MESA 450 Bass Head. In fact, the first 5 MESA amplifiers built in the Lagunitas mountain shack were Bass amps... a piece of trivia little known and overshadowed by our overwhelming notoriety for guitar amplification. But we've always loved the Bass, and have - since day one - been committed to elevating its stature through our art form. The bloodline for MESA bass continued with the first rack-mount chassis bass amplifier in 1980, the D-180. The mid-eighties saw the introduction of the BASS 400 and later in 1988, the BASS 400+ with its stunning Pitch, Punch and Power delivered by an additional 6 x 6L6s to bring the total to twelve 6L6s in the mighty power section.

The 400+ went on to become a classic used by the world's most talented Bassists for two decades. Paul McCartney, Mark King, Stanley Clark, Jack Blades, Michael Anthony, Blasko and Bootsy Collins, are but a few of the international stars that put the 400+ center stage to anchor the band during its 20 year build cycle. Those iconic amps still bring top dollar when you can find one changing hands on the pre-owned market. While MESA has since pioneered an entire line of tube-driven mosfet amplifiers that shored up our place in the Bass market, the discontinuation of the 400+ left a gaping hole in the world of tube Bass amp offerings.

Tone Freaks Rejoice! The BASS PRODIGY Four:88 is the next step in the MESA All-Tube Bass Amp Bloodline. Vastly improved Tone, features, dial-ability, portability, packaging and control over the entire spectrum make the PRODIGY – and its big brother the STRATEGY Eight:88 – an iconic step forward in Bass amplification. With an all-new tube preamp, a 5-position Rotary VOICE Selector, patented Multi-Watt 2-Way Selectable Power, Footswitchable SOLO and VOICE control, Rear Panel TUNER Output, and an all new, high output power section utilizing four KT88s – the PRODIGY is THE tube Bass Amplifier for the new millenium.

FRONT VIEW: BASS PRODIGY™

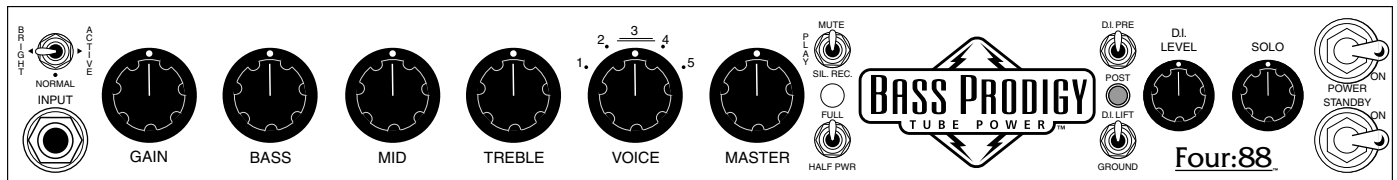

REAR VIEW: BASS PRODIGY™

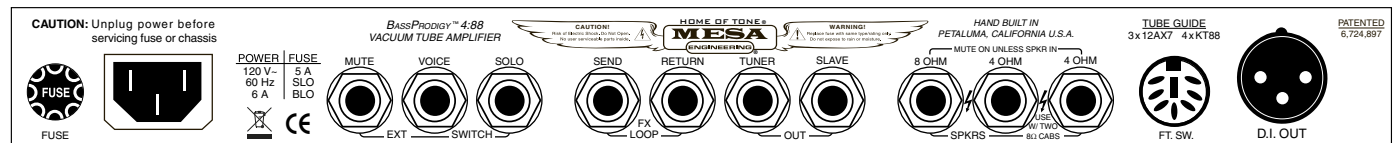

The PRODIGY begins with BRIGHT, NORMAL and ACTIVE INPUT Select choices feeding an all-new tube preamp that borrows subsections from our CARBINE hybrid architecture. This design allows increased control over a broad spectrum of frequencies and incorporates active BASS and TREBLE controls with increased shaping power - while retaining the sweet, musical blend of our traditional passive MID control. In addition to these we've included a reworked-for-tubes version of the CARBINE's 5-position rotary VOICE feature that allows notching or enhancement of specific midrange regions in addition to bass and treble frequency boosting. The VOICE feature puts you instantly in iconic stylistic realms – from elastic, mid-scooped Thumbing to articulate, mid-flat Fingerstyle, to the Classic metallic, scooped American Pick sound – with a flick of a switch. The ability to jump right to these classic “curves” makes re-voicing on the fly in performance situations a snap, is also footswitchable, and adds immensely to the PRODIGY's versatility.

Control over the Tone would be incomplete – at least in our minds – without control over the power as well. So the PRODIGY gives you two choices as to how to utilize the power section. As wattage ratings are often misleading and irrelevant to volume when it comes to describing tube power, the PRODIGY offers FULL and HALF power settings on the MULTI-WATT™ switch. Each of these choices has a distinct tonal color and persona, with FULL delivering the maximum punch, authority and headroom. HALF can deliver some valuable and surprising mid to lower power applications for tube-driven Bass while still offering plenty of volume for a lot of live situations. An important collection of vintage-inspired sounds await you here in HALF POWER ranging from round and warm, to edgy, to clipped and growling – depending how you dish it out from the MASTER, all the sounds in HALF POWER beg to be recorded.

A MUTE/PLAY/SILENT RECORD switch allows convenient Front Panel muting for instrument changes, silent tuning or recording, or any time where signal muting is needed. An AUTO-MUTE circuit is fitted to the Speaker Jacks to protect the transformer and power tubes if no speaker is connected and is indicated by the same Front Panel LED triggered by the mini-toggle MUTE/PLAY/SILENT RECORD switch (Red LED ON = MUTE). The SILENT RECORD setting allows you to safely mute the signal at the Power Amp and use the Prodigy preamp (including processing in the EFFECTS LOOP) to record using the D.I. OUTPUT without sound from the Speaker.

The Rear Panel D.I. OUTPUT signal can be derived from either PRE (your instrument) or POST (the entire preamp) with the Front Panel D.I. Switch. The D.I. OUTPUT signal strength is controlled by the Front Panel D.I. LEVEL located at the far right side of the Chassis next to the SOLO™ Control. And a valuable D.I. LIFT switch can float the Circuit Ground from Chassis Ground to reduce noise into the Console when the Ground references are different.

The PRODIGY incorporates our SOLO™ feature that has become so popular on our guitar amplifiers, which gives you a pre-settable and footswitchable boost for any time you want to feature a specific part or section in a song. The SOLO control can also be used to compensate for an instrument with a lower output due to weaker pickups.

Jumping to the Rear Panel you are greeted with the EXTERNAL SWITCH jacks which make the PRODIGY compatible with virtually any switching system's architecture. These provide for external control of the MUTE, VOICE and SOLO™ features with a master (usually midi) switcher or with any separate “tip to ground” latching-type switch logic.

From there we find the buffered Series EFFECTS LOOP that allows seamless interfacing of your high quality outboard processing. Remember that this sensitive point between preamp and power section is an important Tone stage. Try to use outboard processing of the same caliber as your amplifier. Ignoring this advice will likely result in compromised sound. The Loop is a critical junction/impedance crossroads point between preamp and power and to put inferior foreign objects in the signal path here will produce Tone of the lowest common denominator.

Next you'll find a pair of jacks for the TUNER Output and the SLAVE Level. The TUNER output captures your instrument and preps it for the long journey to the front of the stage or just upstairs to the top of your amp. The SLAVE provides an output for capturing the sound of both preamp and power section for use in connecting your preamp and power section tonality to additional power sections and cabinets for truly coliseum grade rigs.

OVERVIEW: (Continued)

To handle virtually any speaker cabinet scenario, the PRODIGY is fitted with 3 SPEAKER OUTPUTS capable of handling a variety of impedance/cabinet loads. One 8 OHM and two 4 OHM Outputs ensure that you can always find an impedance-correct match regardless of your cabinet choices.

The PRODIGY Footswitch DIN Input resides just to the right of the SPEAKER OUTPUTS and here is where the optional Footswitch & Cable is connected to your amplifier.

Finally, a MESA first – a 2 position BIAS SET switch and trim pot resides on the rear Tube Deck labeled Operate and Set Bias. This SET-BIAS position allows you to check and set your bias quickly and easily for maintenance or when replacing power tubes to set BIAS on the big KT88s. There's no need to take the amp to a technician when it's time to change tubes as this bias method is completely user-serviceable and easy to dial in your bias just right.

INSTANT GRATIFICATION

The PRODIGY is about the easiest amp on the planet to get a great sound from quickly – and with the VOICE Control – several great sounds.. Just set most of the controls at noon...and enjoy! From those settings, may we recommend you sweep the VOICE Control from position 1 to 5 and experience what a difference the various MID voicings combined with bass and treble enhancements can provide.

NOTE: COLD START PROCEDURE: When powering up your PRODIGY from cold, ALWAYS follow this Start Up Procedure: We have found the currently available KT88s require substantially more time than 6L6s or EL34s to warm up to full operating temperature. If you hit them with high voltage with the STANDBY sooner than three minutes, you may hear some crackling as well as a slow volume increase as they get up to full temperature. This subsides once they are fully warm, and while it might not hurt the tubes per se, it is better to warm them up for at least three minutes (or longer) whenever you can.

NOTE: IMPORTANT! – Do Not flip the STANDBY SWITCH in and out of STANDBY mode (on and off) while the amplifier is being played or with any type of signal being amplified. The large amount of current involved in this scenario can damage the STANDBY SWITCH.

1. Begin with STANDBY in the STANDBY Position.
2. Switch POWER to ON and WAIT at least three minutes or longer for the tubes to “warm up”. (With STANDBY OFF and POWER ON, the tubes internal components are allowed to warm up slowly before hitting them with the high voltage controlled by the STANDBY being switched to ON).
3. Flip STANDBY to ON.
4. PLAY!

Following this startup procedure will lengthen the musical life of your power tubes and decrease the chances of untimely power tube failures.

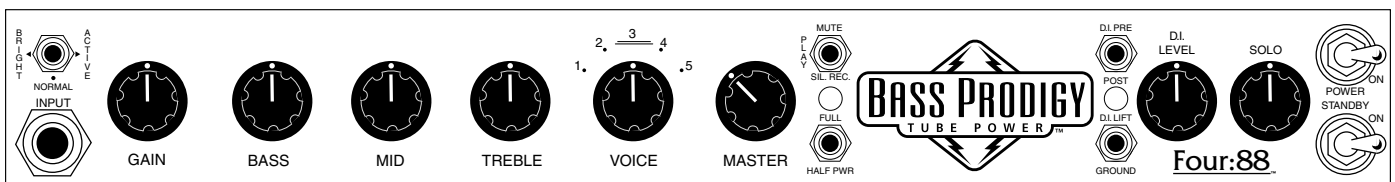

HELPFUL HINTS

IMPORTANT! The SPEAKER OUTPUT Jack's AUTO-MUTE function is triggered anytime there is no Speaker Cabinet (Load) plugged into one of the Speaker Jacks. The amp "knows" if a cabinet is not plugged into a speaker jack and mutes to protect itself from damage. If there is no sound when you turn STANDBY to "ON" – ALWAYS and IMMEDIATELY – **STOP PLAYING** – and check to make sure there is a Speaker Cabinet plugged in. The Front Panel MUTE LED will be illuminated red when either the MUTE/PLAY/SILENT RECORD switch is set to MUTE or SILENT RECORD – OR – when there is no Speaker Cabinet connected to the Speaker Jacks. AUTO-MUTE is also ON when the Set Bias switch is on.

NOTE: IMPORTANT! MAKE SURE YOU HAVE A SPEAKER CONNECTED TO THE SPEAKER OUTPUT JACKS AT ALL TIMES! EVEN THOUGH THE PRODIGY HAS BUILT-IN PROTECTION, DON'T RELY ON THIS ALONE – IT IS A HIGH POWER AMPLIFIER AND NEEDS A LOAD CONNECTED AT ALL TIMES!

NOTE: IMPORTANT! NEVER UNPLUG THE SPEAKER LOAD (Cabinet) WHILE THE AMPLIFIER IS IN USE (BEING PLAYED)!

NOTE: IMPORTANT! DO NOT ATTACH OR USE A CABINET OR CABINETS WHOSE IMPEDANCE/LOAD IS LOWER THAN 4 OHMS. USE OF A 2 OHM LOAD ON THE AMPLIFIER WILL DRAMATICALLY STRESS THE POWER TUBES AND OUTPUT TRANSFORMER, AND MAY CAUSE EXTENSIVE AND EXPENSIVE NON-WARRANTY DAMAGE TO THE AMPLIFIER.

NOTE: IMPORTANT! – Do Not flip the STANDBY SWITCH in and out of STANDBY mode (on and off) while the amplifier is being played or with any type of signal being amplified. The large amount of current involved in this scenario can damage the STANDBY SWITCH.

Though it goes without saying, FULL POWER on the POWER SELECT mini toggle delivers the maximum headroom, punch and perceived "speed" and control over the notes.

The VOICE Control is the most powerful single control on the PRODIGY and delivers many of the characteristics of several different manufacturer's iconic amplifiers in one simple to use control. Use the VOICE Control to take a "broad aim" at the sound/playing style you are pursuing and then focus in and fine-tune with the rotary Tone Controls.

The VOICE Feature "preset sounds" are assembled with these stylistic applications in mind:

1. Slight Mid Scoop/Huge Low End: Funk/Thumbing/Slap
2. Subtle Wide "Q" Bass Boost-Approximately 20Hz – 180Hz: Smooth R&B/Fingerstyle
3. Flat: Articulate Rock Punch/Fingerstyle
4. Mid Scoop/Bass Boost/High Boost: Classic Rock/Pick, Fingerstyle, Thumbing
5. Radical Mid Scoop/Bass Boost/High Boost: Aggressive Rock/Pick, Hyper Slap/Thumbing

Sometimes less is more. Don't fall prey to the classic Tone Trap... EQ HANGOVER. Don't chase great Tone around in circles. Instead use your IQ and constantly reference a "less altered state of play". By going back and forth to a more "flat" or "conservatively voiced" setting you will avoid ear fatigue and end up with a more balanced sound.

The SOLO Feature can be used to not only boost your level for featured parts, but as an additional MASTER VOLUME to compensate for different footswitchable VOICE settings as well.

The D.I. OUTPUT will have signal present when in the PRE selection even when STANDBY is used to mute the signal to the power section (STANDBY position) as this is the direct signal straight from your instrument before it goes through the amplifier.

The Cooling Fan is equipped with a thermostat that allows for different speeds depending on the operating conditions (temperature) of the output transformer and tubes. Don't be alarmed if the fan speed (and associated noise) increases while you are playing. This is normal and essential to your amplifier's wellbeing and reliability.

Now that you have an overview of your PRODIGY and some hints to achieve a great sound fast, let's take a deeper look at the controls and features of this mighty little Bass powerhouse.

FRONT PANEL: (CONTROLS & FEATURES)

INPUT: This jack is the instrument INPUT and it feeds the first tube stage in the tube preamp of the PRODIGY. Both passive as well as active instruments are provided for with a specific setting on the 3-position INPUT SELECT switch.

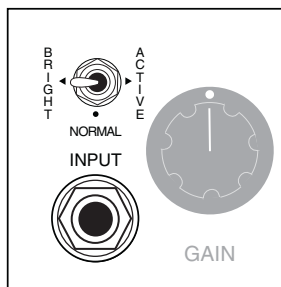

INPUT SELECT: BRIGHT/NORMAL/ACTIVE This 3-position switch allows selection of three different Input configurations, two of which are voicing options and a third that offers an Input Pad for Active Instruments. Select the option that best suits your tonal/stylistic needs and impedance/headroom requirements.

BRIGHT This is the normal INPUT (to us anyway)- and while “normal” is a relative term – this setting would usually be the first choice for most Passive instruments. As you might imagine, the BRIGHT selection offers a brighter, more detailed Tone and can also give the impression of a more responsive or faster feel – which Passive Instruments might benefit from. This Input Mode would be the choice anytime you’re looking for a more present or forward sound with enhanced top end characteristics and a more detailed spectrum of upper harmonics. While the name suggests that this position might be better suited to traditional or passive instruments, don’t be afraid to try BRIGHT for an exciting sound with Active Basses as well. Just keep in mind that the range of usable, unclipped headroom on the GAIN control will be lower if you use BRIGHT with an active instrument. BRIGHT provides a snappy, alive sound that has more bounce and clarity for vintage style basses that is really fun to play. The impression of headroom and more full-range EQ curve of the BRIGHT Input creates a crisp, superbly clean sound with these more traditional instruments that will likely take them down some new avenues. You may also want to use BRIGHT if the cabinets you’re using don’t offer high frequency horns or tweeters and you’re looking for more detail in the high end.

NORMAL provides a purposeful “Low-Fi” sounding alternative to the crisp and detailed sound of the BRIGHT Input setting. The NORMAL input is also a great choice if your bass or cabinet (or both) leans toward being a little on the bright side or if you find the Prodigy to sound bright with other elements of your rig. A quick flip of the switch and the Prodigy is tuned to your playing style or other aspects of your rig. NORMAL features a rounder, warmer Tone that is perfect for old school sounds and classic passive Basses. This setting may also be preferable for overdriven or clipped sounds as the less prominent top end will produce a more musical clip and help avoid ratty or buzzy distortion characteristics. NORMAL can also provide a warmer sound for modern Basses with higher output pickups, but will probably start to run out of headroom and break up sooner - possibly before you want them to. It will not hurt the amplifier to run active instruments in the NORMAL Input and in fact, you may want to use this to your advantage in certain musical scenarios. However, if you are looking for the most Hi-Fi tonal response and greatest headroom you will likely find better performance by using the ACTIVE Input.

ACTIVE provides the proper padded Input sensitivity for instruments that incorporate an on-board preamp and/or pickups that utilize active electronics. This jack can receive the highest signal level before clipping and therefore provides the greatest headroom for these higher output instruments. EQ-wise, ACTIVE is voiced much like the BRIGHT setting and provides the full spectrum of upper harmonics. This clarity and detail nicely reinforces the higher headroom nature of this Input setting. While there is more headroom - and therefore, ACTIVE requires a hotter signal to bring the whole amp to full power - don’t be afraid to try it for a different sound with passive Basses as well. One thing is for sure, you won’t be running out of clean headroom at the INPUT if you run your passive instrument in the ACTIVE setting. You can use this to your advantage when looking for the cleanest possible sound with traditional Basses. Just keep in mind you may see higher settings on both GAIN and MASTER than you’re accustomed to in order to achieve the volume you want for this hyper-clean Tone.

THE CONTROLS

GAIN

This control determines the overall character of the sound along with input gain and sensitivity. The lower regions of the control (below 12:00) offers the cleanest sounds and greater headroom with a scooped, brighter personality. The upper harmonics come through more prominently in this area of the control making the top end sound more transparent and crisp. This region is especially useful for funkier stuff when thumbing is in order. It keeps the rubber-band feel intact in the lows and mids while voicing the snap just high enough to avoid harshness, or the dreaded “gak” when the G string is plucked.

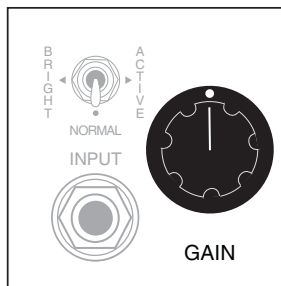

As the GAIN control is increased past 12:00 a richer, “well-rounded” and more blooming voice becomes dominant. Headroom starts to diminish in increments until eventually, a tube overdrive sound appears as the 12AX7 input preamp tube is driven into saturation.

The region between 12:00 and 2:30 is where classic, warm tube sounds reside. Within this narrow band, you will discover a world of old-school tones. Tiny increments here produce subtle, but important differences in the attack characteristic, which in turn, can feel like changes in the time domain.

By experimenting with the setting of the GAIN control, you can actually voice the amp to feel as if it bounces just ahead of the groove (10:30 – 12:00) - or lays back a little deeper to produce a more ‘Fatback’ feel with tube drive (12:30 – 2:00). The difference in attack and sustain produces striking results as to how the bassist - and in fact the whole band - perceives things in the time domain.

BASS

This control is responsible for the basic mix of low frequencies in the tube pre-amp. The BASS control is an “active” control - as opposed to a “passive” style control. This means that a center “Q” point has been chosen for this control that allows you to either boost or cut a range of low end centered on that frequency. While there is a specific frequency that the Bass control “centers on”, the frequencies and harmonics on either side of this center Q point are affected in a diminishing “bell shaped” curve as you sweep it one direction or another.



The BASS control is actually a gain and frequency control all rolled into one with the “Q” center at 55Hz. As mentioned above, though it is centered here, frequencies (harmonics) in both low and high directions are affected because of its broader-band nature. Twelve o’clock (NOON) on the BASS control delivers a basically “flat” response (no boost/no cut). As the BASS control is increased past 12:00 (NOON), it produces a 6db per octave boost in gain starting at the center point of 55Hz and tapering gradually to the edges of the broad Q’s bell-shaped curve from 20Hz on the low side, all the way up to

321Hz on the high side. At 5:30 on the bass control a +6db increase in gain is possible. As the BASS control is dialed below 12:00, 55Hz and all associated harmonics are reduced and eventually notched almost completely out of the signal path. This lower range of the control delivers a 6db per octave “cut” centered at 55Hz going down to 20Hz with an overall “cut gain” of -10db possible as the control reaches 7:30 (off).

This type of active rotary control makes it possible to achieve bass control and characteristics far beyond that of a conventional passive type control. It can increase the low end to an almost absurd level and then, with a flick of the wrist, dip it to near transistor radio skinniness. Needless to say, with any control this powerful a certain amount of finesse must be applied to achieve musical results.

MID

This is the only passive style control in the string of rotary tone controls. This scheme was chosen for its inherently musical blend and for the way the passive style midrange control - with its wide footprint and smooth taper - fills in the “holes”. Unlike the BASS, this control is a cut only, and while it can competently remove this broad spectrum of midrange from the mix, it cannot provide the extreme focused attenuation of an active style control.



You will find that this passive, broad-band control works really well for shaping the midrange frequencies and imparting a natural earthiness and character that is the perfect counterpart to its active style neighbors. It’s hard to dial wrong with this more forgiving approach - as it gives you the ability to punch through a mix or sweeten and smooth out the sound by adjusting just one control.

THE CONTROLS *(Continued)*

Another useful property of the Passive MID when used above 12:00 is that it starts to impart a furry, tube growl as it is increased and actually pushes things toward the threshold of clip at higher settings... especially in the #3 “Flat” VOICE Position. Use this to your advantage when searching for aggressive Rock sounds with an edge or R&B Tones that have just a hint of tube saturation.

For radical and specific scooping of the midrange frequencies in modern R&B and Funk styles, there is plenty of notching power that is infinitely more accurate stylistically, to be found in the VOICE Control. Because of this, we opted for the tried and true passive style midrange control that has been working great in all of our amplifiers for decades. It's hard to improve on a classic.

TREBLE The TREBLE is also an active-style control like that found in the BASS and it was chosen for its ability to radically shape the upper harmonic region. Like the BASS, it also has a center Q point with frequencies (harmonics) above and below, responding in harmony in a bell-shaped curve as it is dialed for either cut or boost.

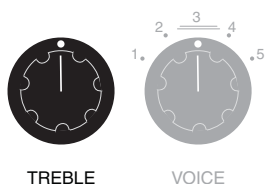

As the TREBLE control is increased past 12:00 (NOON), it produces a 6db per octave boost in gain starting at the center point of 3.2KHz and tapering gradually to the edges of the broad Q's bell-shaped curve from 723Hz on the low side and all the way up to 6KHz on the high side. The maximum boost available from 12:00 (Flat) is 5db. Dialing the TREBLE below 12:00 produces a 6db per octave cut centered at 3.2KHz and decreasing in strength down to 723Hz and out to 6KHz. The maximum “cut” attenuation of -10db is reached at the bottom of the control (7:30/off). The ability to cut these frequencies more radically makes it possible to obtain incredibly rich and warm old-school R&B and Jazz sounds

that rival any of the classic recordings of the day. This broad Q scheme lends a sweetness of sound when boosted while retaining all the focus and simple usability associated with a traditional passive TREBLE control.

The active TREBLE control completes the rotary tone control string to create a powerful and extremely accurate network to use as your fundamental tools for Tone shaping. It's no wonder many first-time PRODIGY players make the comment that just these three controls (even set at noon) — combined with the GAIN — create the best tone they have ever heard!

NOTE: As with the BASS control, may we remind you that a control of this type, with its increased power, should be used with finesse (in the TREBLE's case, almost more so, because higher frequencies seem louder to the ear and are generally more painful when set to extremes). Another reason to use care is that high frequencies tend to increase the ambient noise floor when set too high. This is then exacerbated if the MID control is combined for added top end boost. Dial with care and music in mind.

VOICE This simple to use feature puts the shaping power of a parametric EQ at your fingertips (without the learning curve) and allows you to access some of the world's most iconic bass sounds instantly either via the rotary switch or optional footswitch.

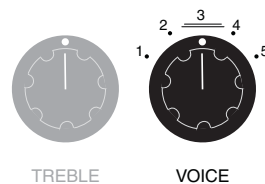

The 5-position rotary allows you to select from four distinct and different voices aimed at all the classic Bass sounds. Most of the dramatic changes occur in the midrange where the basic character of a sound is determined right away. There are three positions that feature scooped midrange of different frequencies (Positions 1,4 & 5) — two with increased lows (Positions 1 & 2) and two positions that utilize scooped higher mids with boosted lows and boosted highs to achieve their curve (Positions 4 & 5). Position 3 is basically a “Flat” sound with no midrange cut or boost – so you can think of that as a “BYPASS” for the VOICE feature.

Below is a synopsis of the 5 voicing choices (Modes) found on the VOICE control:

1. Midrange scoop (centered around 400-500Hz) accompanied by a boost in low end. Excellent for dramatic thumping/slapping styles or smooth chording.
2. Subtle Bass Boost from 20Hz-180Hz. Great for R&B and anytime you want to widen a sound.

3. Voice Feature Bypassed – “Flat” with Tone controls set at 12:00.
4. Gentle Midrange scoop (centered around 600Hz) and low end boost with increased high end. Good choice for articulate Rock styles with Fingers or Pick. Tracks your playing with articulation and enhanced definition.
5. Radical Mid Scoop (centered around 600Hz) and low end boost with increased high end. ‘Piano String’ clarity, great for aggressive Rock Styles played with Fingers or Pick or Hyper-Funk Slap or Thumbing Styles.

Keep in mind these positions use a medium Q width to avoid a notchy sound and retain an organic quality. There will be some cut or boost on the adjacent frequencies. Once you have selected a VOICE mode to use, consider fine-tuning the sound with the standard tone controls.

Remember that the rotary tone controls might seem to react differently than they do when the VOICE feature is BYPASSED (set to position 3) — as the basic character of the sound is altered substantially in positions 1, 2, 4 & 5. The Tone controls are still centered in their respective regions, but the way they interact within the landscape of different frequencies being cut or boosted by the VOICE mode causes a perceived shift in their response.

MASTER

The MASTER control is the feed to the power section and determines the overall playing volume of the PRODIGY as well as determining the FX SEND Level. An optimum setting will be partially determined by the setting of the GAIN control as well as the entire Tone Control network – and how loud you want the amp. All these controls affect the signal strength at the end of the preamp and can make the MASTER control very sensitive. The MASTER allows you to set the preamp’s GAIN control across a wide range of input headroom possibilities — from completely clean to tube overdrive — and compensate for these extremes, giving you independent control over the playing volume.

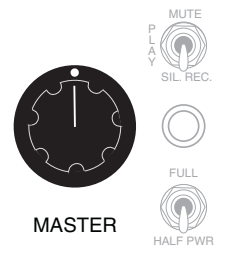

NOTE: Remember to use caution with the MASTER as it is the gas pedal for the significant power available with the Prodigy. We suggest a zero setting at each power up to avoid surprise damage to speakers and ears.

MUTE/PLAY/SILENT RECORD

This mini toggle provides a MUTE Mode for silent tuning, cable swapping or any time you need to mute the sound without powering down. The SILENT RECORD MODE allows for silent (no live speaker) recording when using the D.I. OUTPUT interface to a console. This function mutes the signal at the input of the Driver stage and also (for protection of the transformer and power tubes) at the SPEAKER OUTPUT jacks. The FX LOOP signal is derived and returned before this mute point, so all your processing will be intact at the D.I. OUTPUT when using the SILENT RECORD feature. Use the SILENT RECORD position to shut off the signal to the power amp and speakers and PLAY to use the PRODIGY in a normal (live) scenario. There is an LED indicator just below the toggle switch that illuminates when the MUTE or SILENT RECORD Modes are engaged.

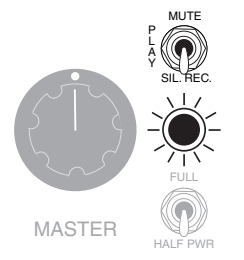

The MUTE Mode can also be engaged from the optional PRODIGY Footswitch by hitting the MUTE button located there.

A dedicated trigger jack for the MUTE Mode is located on the Rear Panel in the EXTERNAL SWITCH section. The MUTE Mode can be triggered from there via a remote switcher such as any standard ¼” tip-to-ground latching-type switch. This type of control logic is standard on nearly all master switching units on the market.

THE CONTROLS *(Continued)*

MULTI-WATT™ Switchable Power: FULL / HALF PWR

As you might have guessed, this switch allows you to select between two distinct ranges of power, enabling you to better tailor the output response of the PRODIGY to the preamp sounds you have dialed up and/or the venue you're playing in. In some cases you will want to use it to create an appropriate volume level, while in other scenarios to further authenticate a certain sound, style or vibe.

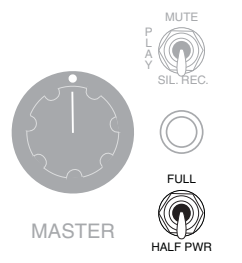

While the two settings – FULL and HALF – refer to both power rating and available headroom, each of these also has an effect on the Tone and personality of the sound. You'll quickly learn to use these choices as part of your Tone palette along with the rotary Tone controls and VOICE Feature to craft sounds that are appropriate in volume and clarity as well as authentic in shape and feel.

FULL incorporates all four power tubes to create the maximum power and headroom – approximately 250 watts RMS of tube power – that sounds and feels more like 500. This is the choice any time you need the maximum clean transient attack, clarity and headroom. FULL will also track complex rhythmic passages with the most accuracy as it has the quickest recovery time between notes. Tone-wise, FULL has the best balance of punch and authority, sparkle and detail and creates a “Hi-Fi” experience, particularly when used with the BRIGHT input selection. Tight delivery and tracking in the low mids and bottom end is beautifully integrated with top end detail and angelic sounding upper harmonics. Up here the air is fresh and inspiring as only an all-tube circuit can create.

HALF PWR utilizes two of the four KT88s to provide approximately 125 watts of sweet, tube power. This option has a less shimmering top end, warmer detail and a little less emphasis on midrange punch. HALF can be pushed into a furry clip in medium size venues for added Rock attitude or for an old school R&B sound that can meet lower to medium headroom requirements. HALF is the perfect Studio power mode. Clean enough, but not too clean. It makes up, in personality and color, what it lacks in brute power. It also can save you money on tube replacement costs. By using the HALF position for your applications that don't require maximum output and headroom, you can lengthen the interval between re-tubing if you employ power tube rotation (swapping the ones used in HALF Power with the ones that remain in STANDBY during HALF Power operation). If you do end up using HALF for much of your playing, you can rotate the “unused” tubes and get twice the Tone-full life out of a set of output tubes. (See the TUBE TASK CHART in the Rear Section of this Manual to identify the tubes in use during HALF Power Operating Mode).

NOTE: When using the HALF power setting, to obtain the maximum headroom and power and retain tight, punchy attack characteristics, move an 8 Ohm speaker cabinet to the 4 Ohm SPEAKER OUTPUT on the Rear Panel. (See the SPEAKER OUTPUT section later in the manual for more details and options on speaker connections in HALF Power.)

However you decide to utilize the PRODIGY'S Multi-Watt™ Switchable Power, it adds a level of versatility that's hard to beat in Tone, adaptability and authenticity. Be sure to experiment enough to learn the personalities, applications and boundaries of these classic power choices so that you can apply them quickly and appropriately to your style and your musical endeavors.

PRE/POST: D.I. OUTPUT SELECT

This switch toggles the output signal at the D.I. OUTPUT between a POST signal – where the entire preamp and control settings affect the sound – and a PRE signal – where the instrument signal is fed directly to the D.I. OUTPUT, bypassing the preamp and tone controls.



PRE is the direct sound of your instrument before it goes through the preamp. In this setting, the controls will not affect the signal at the DIRECT OUTPUT. The PRE setting is useful for large venues when the sound you have dialed up for your optimum stage tone might have too much low end for the front of house engineer to balance through a large PA where there are subs employed.

POST gives you the entire preamp signal including INPUT SELECT, Tone Controls, the VOICE Mode selection and processing in the Effects Loop. POST is appropriate for recording situations where you want to capture the closest thing to what you are hearing when you play, or live situations where the sound engineer requests your “stage sound” as a Direct feed to the front of house.

NOTE: The D.I. OUTPUT will have signal present when in the PRE selection even when STANDBY is used to mute the signal to the power section (STANDBY position) as this is the direct signal straight from your instrument before it goes through the amplifier.

NOTE: POST does not capture and include the power section of your amplifier.

D.I. LIFT / GROUND This 2-position mini toggle offers the ability to lift the Circuit Ground from the Chassis Ground, effectively isolating the path to Ground for the PRODIGY circuit. This can be very helpful in live sound front of house or Monitor applications as well as in Recording environments.

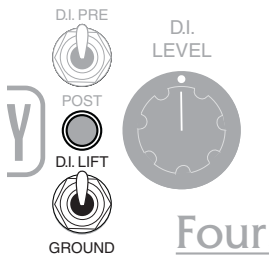

LIFT isolates the Circuit to Chassis Ground, preventing these types of ground loops when interfacing to consoles.

GROUND connects the Circuit Ground to the Chassis and should be used whenever possible. Use this position at all times when you are NOT connecting the D.I. OUTPUT to a console.

Sometimes – not always – this will help you isolate and remove unwanted hum or buzz from the equation. Remember that there are a myriad of noises and hums that can be caused from many sources, including things beyond your control elsewhere on the AC Line you are connected to (outside your house, studio or venue). The D.I. LIFT/GROUND switch can't cure those other outside factors, but it can relieve one of the more common sources of hum found when interfacing to Consoles that arises when the amplifier's Ground and the Console Ground create a loop.

D.I. LEVEL This Control determines the signal strength at the Rear Panel XLR D.I. OUTPUT Jack. We have located the D.I. LEVEL on the Front Panel to offer you easy adjustment of the D.I. Level at Sound Check or even during a performance. The D.I. OUTPUT on the Rear Panel is optimized for use directly into mixing consoles and the D.I. LEVEL Control will allow for more than adequate signal level and plenty of room for adjustment within that window.



NOTE: IMPORTANT! It is a wise practice whenever interfacing with Consoles – whether Recording or Live Sound – to ALWAYS begin your set-up regimen by zeroing out the D.I. LEVEL control BEFORE flipping the POWER switch to the ON position. This will prevent damage to the Console, Speakers or bystanders' ears should the D.I. LEVEL accidentally be set too high. This practice allows you to bring up the D.I. LEVEL slowly while the Engineer monitors the incoming signal strength and safely reaches an optimum level.

It is also wise to follow this regimen in reverse. Make it habit to zero out the D.I. LEVEL at the end of each performance or session. If you are in a hurry when you set-up to use the PRODIGY you'll avoid an embarrassing and sonically unpleasant mistake.

SOLO CONTROL™ Your PRODIGY is equipped with our patented SOLO™ Feature that provides you with a pre-settable, footswitchable boost for when it's time to step out and showcase important parts during a performance. You can use the (optional) PRODIGY Footswitch to engage this feature or you can trigger the SOLO LEVEL via a tip-to-ground latching switch connected to the Rear Panel jack labeled SOLO in the EXT. (external) SWITCHING jacks section (left rear).

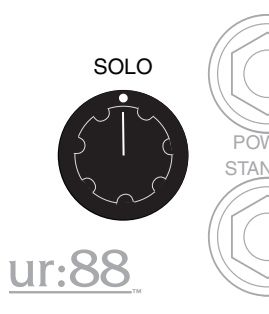

This feature can be used to increase the playing volume to the amount set by the SOLO control when engaged. To use SOLO, simply connect your Footswitch or external trigger, set your playing volume with the MASTER control, hit the SOLO button on the Footswitch, and set the desired amount of boost with the SOLO control. Now you have the added flexibility of a second "MASTER" control that you can call up at any time from the Footswitch.

NOTE: The SOLO may not be used to achieve a volume level lower than that set by the MASTER control... it is a boost only feature.

NOTE: The SOLO control is optimized for performance level operation and therefore provides the best functionality in the middle range of the MASTER control. It is normal to experience decreased effectiveness of the SOLO Feature at both the lowest and highest regions of the MASTER control.

THE CONTROLS *(Continued)*

POWER This switch controls the incoming AC Line power to the PRODIGY. Make sure you are connecting the PRODIGY to a grounded outlet with the proper voltage rating present (120V / 60Hz AC for US Models).

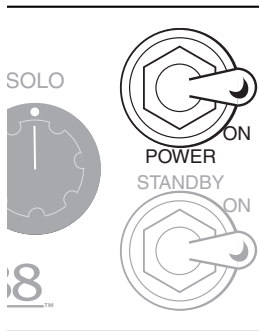

Never Alter your power cable! This will void your warranty and put you at risk of damaging your amplifier and increasing your risk of electrical shock.

NOTE: COLD START PROCEDURE: When powering up your PRODIGY from cold, ALWAYS follow this Start Up Procedure: We have found the currently available KT88s to require substantially more time than 6L6s or EL34s to warm up to full operating temperature. If you hit them with high voltage sooner than three minutes you may hear some crackling as well as a slow volume increase as they get up to full temperature. This subsides once they are fully warm, and while it might not hurt the tubes per se – it is better to warm them up for at least three minutes whenever you can.

1. Always begin with the STANDBY switch set to STANDBY.
2. Switch POWER to ON and WAIT at least three minutes or longer for the tubes to warm up. With STANDBY OFF and POWER ON, the tube's internal components are allowed to warm up slowly before hitting them with the high voltage controlled by the STANDBY being switched to ON.
3. Move STANDBY to the ON Position
4. Play (your butt off)!

Following this startup procedure will lengthen the musical life of your power tubes and decrease the chances of untimely power tube failures.

You may leave the POWER set to ON and use the STANDBY to cool your amp down and put it in an “idle state” during set breaks. This is actually easier on the tubes than turning the POWER completely off, only to fire it back up again 15 minutes later. The shock of in-rush current at the instant of POWER ON puts more stress on them than staying at idle (in STANDBY) once they are warm. This scheme will ensure the longest tube life and best reliability from your PRODIGY.

STANDBY This switch controls the high voltage on the tubes. When set to OFF, this switch puts the PRODIGY in an “idle” mode that is essential at “cold power up” and very handy — even frugal – during breaks in performance. Be sure to follow the cold-start procedure outlined in the previous section on POWER to get the best tube life and reliability from your PRODIGY.

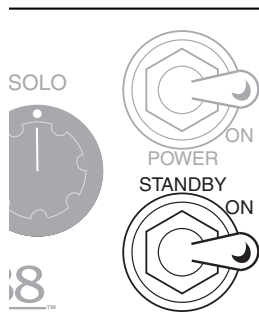

Use the STANDBY to mute the signal anytime you take a break or want to do something other than play for a short time but know you will return soon... like a few minutes or a ½ hour or so. If you know you won't resume using the amplifier within a reasonably short time, go ahead and turn the POWER switch off and save the electricity and your tubes. Just be sure to follow the Cold Start procedure every time you wish to play. It will save your Tone and your money.

NOTE: IMPORTANT! – Do Not flip the STANDBY SWITCH in and out of STANDBY mode (on and off) while the amplifier is being played or with any type of signal being amplified. The large amount of current involved in this scenario can damage the STANDBY SWITCH.

Well that about wraps it up for the Front Panel Features and controls. Now let's review the Rear Panel and get familiar with those features.

REST AREA

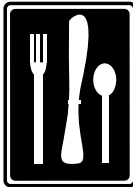
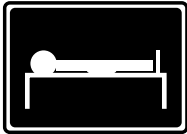

REAR PANEL CONTROLS

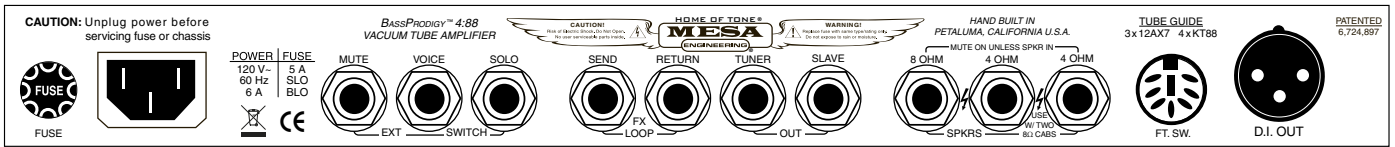

AC MAINS FUSE

The AC MAINS Fuse for the PRODIGY is located at the far left of the Rear Panel. Should your Fuse ever blow from either a surge in the line voltage or from a faulty power tube, REPLACE IT ONLY WITH A SLO-BLO TYPE FUSE OF THE PROPER RATING AS LISTED NEAR THE FUSE HOLDER. THIS IS EXTREMELY IMPORTANT AS THE PRODIGY DRAWS A SUBSTANTIAL AMOUNT OF CURRENT.

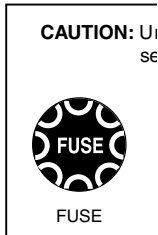

FUSE Rating for USA/Japan - 5A S.B.

FUSE RATING AND REPLACEMENT

A little known fact is that slo-blo fuses, as used in tube amplifiers, are rated for 135% of stated value for one full hour of operation. This means a 5 amp rated fuse will carry almost 7 amps for one hour before blowing. In order to comply with UL "fault condition testing" we have furnished a fuse value that will provide trouble free operation while at the same time being low enough to protect your power transformer from over heating should it ever get too hot (extremely unlikely).

In addition, the high voltage plate of each KT88 is protected via a special fusing type resistor to remove that tube from the circuit should it experience a hard short-circuit type failure. This will limit damage and likely allow the amp to continue functioning, getting you through the gig, though "on one less cylinder". A hard tube short may occasionally damage the ceramic tube socket and your amp should be serviced right away by a competent Authorized Mesa technician in the unlikely event this occurs.

During two years of prototype development and overall amp torture, the ONLY tube failures occurred when the amp was hit with a big bass note... and no speaker was connected. To protect against such accidental misuse, we have added internal switches to the speaker jacks that trigger the MUTE circuit until a plug is inserted into any one of the speaker jacks. For this system to be totally effective, you must insure that the plug is FULLY inserted into the amplifier and that the other end of the speaker cable is also connected to your cabinet (duh!). Failures resulting from "no load" misuse will not be covered under warranty as they constitute gross user error.

NOTE: We cannot overemphasize the importance of making sure you have a speaker properly connected to your PRODIGY AT ALL TIMES. The higher plate voltages of KT88 power tubes creates potential for expensive repair bills and premature tube failures with no speaker load connected. Never play loud or long if you hear no sound from your amp and always check the speaker connection first in any no sound situation.

NOTE: Remember – the Front Panel MUTE LED Indicator will illuminate as a safeguard against a no load condition when there is no speaker jack connected to the SPEAKER OUTPUT! If you see this light on – CHECK YOUR SPEAKER OUTPUT and PUT A LOAD (cabinet) ON ONE if necessary BEFORE TURNING STANDBY ON!

POWER CABLE

The IEC Removable AC cord that is supplied with the PRODIGY makes set-ups and tear-downs after the gig a snap. Make sure the AC cord is firmly in its socket (receptacle) before powering up the amplifier. Also, make sure the AC wall outlet you are connecting to is a reliable source of 120 volt AC power. Additional heavy-duty cords are available from MESA should you ever need one... simply call us and we can send one directly to you for a nominal charge (plus shipping).

Unplug power before servicing fuse or chassis

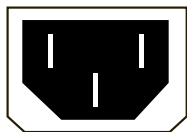

POWER
120 V-
60 Hz
6 A



NOTE: The PRODIGY draws a substantial amount of AC current due to its high power and robust power transformer. Having multiple amplifiers connected to the same AC source (power strip or even the same 15 amp Circuit), using long extension cords or playing at extreme volumes can increase the likelihood of a circuit breaker tripping. If a breaker does trip, check to see what else may be on that same circuit (refrigerator, fans in use, other amplifiers, etc.) and remove any “unconditioned” power strips, extension cords and amplifiers and try to plug the PRODIGY directly into the wall Outlet – preferably one with only the PRODIGY or very little else on that circuit.

NOTE: NEVER ALTER THE 3-PRONG POWER CORD IN ANY WAY. Doing so will void your warranty and increase the risk of electrical shock.

EXT (EXTERNAL) SWITCHING

These three ¼” phone jacks allow external, remote switching of the MUTE, VOICE and SOLO Features for easy interfacing with a master (usually MIDI) switching system. Most MIDI controllers and switching interfaces utilize simple tip-to-ground latching-type switch logic, which is industry standard and provided for on virtually all brands and types of master switching systems on the market.

BASSPRODIGY™ 4:88
VACUUM TUBE AMPLIFIER

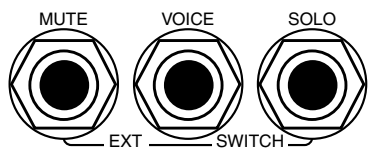

These jacks may also be used with single button tip-to-ground latching-type footswitches to isolate any of the three features for individual control. This allows those who don't need all three features to be footswitchable to just use single or smaller boxes on their pedal board for just the features they need to control. There are common individual Control Footswitches offered by many manufacturers and Mesa also sells single button tip-to-ground footswitches

for these functions as well. You can purchase Mesa single button footswitches from your local Mesa Authorized dealer or direct from the factory.

NOTE: Use unshielded cables for the EXT. SWITCHING functions.

NOTE: The EXT SWITCHING Features are controlled by standard tip-to-ground latching-type logic.

SEND / RETURN (EFFECTS LOOP)

NOTE: To avoid any loud and potentially dangerous pops and noises, set the amp to Standby before connecting or disconnecting any effects to the Send or Return jacks. This will prevent any potential damage to speakers, console inputs or ears.

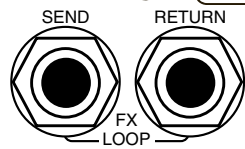

These two ¼” jacks provide the interface for outboard effects devices and pedals and offers a way to use these processors with the least amount of degradation to your Tone. The LOOP is a critical Tone path in the PRODIGY and is best used for time-based effects (delay, chorus, flange, etc). Effects like overdrive, distortion, wah, envelope or compression often offer substantial gain increase potential beyond UNITY GAIN if used at extremes. Use of these types of effects in the LOOP can be a cause of issues ranging from microphonics, squealing, breakup, unwanted distortion or reduced headroom, just to name a few, if UNITY GAIN is exceeded via your effect(s) output into the FX RETURN. That said, many players successfully use compression (or for that matter, any of these devices) in the LOOP to control the dynamics there instead of between the Bass and the INPUT, although usually very sparingly. There is no right way to apply compression (or the other above mentioned effects), so where you place them in your signal path is up to you. Typically though, the devices mentioned above sound better and are more widely usable when used on the “Front End” and not in the LOOP.

The Effects Loop is a junction point between the end of the preamp and the driver stage to the power section and these jacks are

REAR PANEL CONTROLS *(Continued)*

wired in SERIES with the signal. This means that the entire signal goes through the LOOP. The SEND jack will feed the signal out of the preamp without interrupting it. The RETURN jack will break the path and interrupt the signal.

When nothing is plugged in to the SEND and RETURN jacks the EFFECTS LOOP is effectively bypassed and the signal is unaffected by any loop circuitry. Because these jacks are stereo-type jacks and have two elements in them, be sure you firmly seat the cables all the way in to the base of the “Ring” (shaft part) on the ¼” phono plug to ensure a good connection.

NOTE: DON'T COMPROMISE YOUR TONE! The EFFECTS LOOP is wired in SERIES with the dry signal. Use the best quality processors and pedal effects possible in the EFFECTS LOOP to ensure a good impedance match and minimal signal degradation. Also use the best quality (low capacitance) cable possible of the shortest length to minimize the loss of high end or punch (TONE). We suggest 1-3 feet of FX related cabling, at most, to preserve tonal integrity. Everything you put in your signal path affects your sound – so use the best!

TUNER

This jack captures the sound of your Instrument right off the INPUT jack - before it enters the preamp - and sends it directly to the TUNER output providing a feed for tuning devices. It is a buffered signal so longer cable lengths are not an issue.

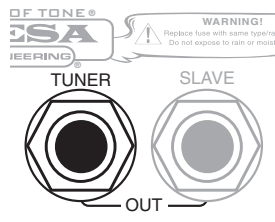

You may mute the audio signal at the SPEAKER OUTPUTS by using the TUNER MUTE function on the optional PRODIGY Footswitch or, by triggering the MUTE feature via the EXT. SWITCHING jacks with an external master switching device or a single tip-to-ground on/off latching footswitch.

NOTE: Use shielded audio cable for connecting the TUNER Output to an external tuner.

SLAVE

This jack is the output for the SLAVE circuit. Its signal is derived from the SPEAKER OUTPUT and then padded down substantially to optimize it for driving additional amplifiers such as an additional PRODIGY or other power amp for large venues

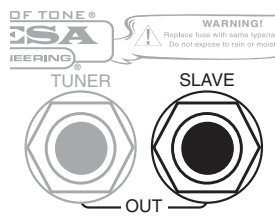

The primary application for the SLAVE is to add additional power while using just the one PRODIGY preamp. It is common practice to use the SLAVE jack to feed the EFFECTS LOOP RETURN jack of other PRODIGY or STRATEGY amplifiers and bypass their preamps. This scheme provides minimal “tweaking” when you want to add power and also allows for a backup preamp should you ever need one (tube failure, etc.).

While it is possible to feed Mixing Consoles with the SLAVE, it is not recommended as it is not voiced accordingly and the signal level is on the hot side. Use the D.I. OUTPUT whenever possible for interfacing to Consoles as you will achieve better results.

NOTE: IMPORTANT! Always begin using the SLAVE by setting the Front Panel MASTER to 7:30 (OFF) and increase it slowly as this approach will help protect INPUT Stages, Speakers and most importantly... Ears!

NOTE: Once a signal is taken out of the SLAVE OUT it can not be inserted back into the amplifier anywhere as a feedback loop will occur, producing a loud squeal akin to holding a microphone up to the PA Speaker.

NOTE: Use only shielded high quality (low capacitance) audio cable when taking a signal from the SLAVE OUT to other power amplifiers or effects..

FOOTSWITCH (OPTIONAL)

An **optional** PRODIGY Footswitch is available that provides remote control of the VOICE, SOLO, FX and MUTE/TUNE features. It also features a ¼" TUNER OUT jack on the left side that provides for connection of a tuner at the location of the Footswitch. When MUTE is selected on the Footswitch the signal at the SPEAKER OUTPUTS will be silenced but the signal at the TUNER jack on the Footswitch will still be active so you can tune your instrument silently without going back to your amplifier. The VOICE button allows you to toggle the VOICE feature from Mode (position) 1, 2, 4 and 5 back to the "Bypassed/Flat" setting of Mode #3.

TUBE GUIDE
3x12AX7 4xKT88



FT. SW.



D.I.

The female 8-pin DIN receptacle is for the **optional** PRODIGY Footswitch. Connect the 8-pin DIN cable to this receptacle when the PRODIGY Footswitch is to be used to control the MUTE, VOICE, LOOP and SOLO. Make sure the cable is oriented correctly - with the pins lining up with the sleeves in their jacks and then be sure it is properly seated (all the way in) when inserting the cable into the 8-pin DIN receptacle and the footswitch.

NOTE: NEVER force an improperly aligned cable! It can be connected easily when properly aligned.

NOTE: It is good practice to secure the Footswitch cable so that it will not be stressed should someone step on, trip over or pull the cable sideways in some manner. This could cause damage to the pins on the male end of the cable or even possibly the sleeves within the DIN jack. The simple, time tested gaffer's (duct) tape is a good idea even if you and your band mates don't move around much during performance – someone else might.

SPEAKER OUTPUT (WITH AUTO-MUTE PROTECTION)

These three jacks are the ¼" SPEAKER OUTPUTS for the PRODIGY and they are responsible for delivering it's massive Tone and Power to your cabinets of choice. One 8 OHM and two 4 OHM jacks allow interfacing of almost any speaker set up and ensures proper loading of the Output Transformer and Tubes. For more ideas and instruction on connecting your cabinets properly, see the diagrams in the Rear of this Manual on SPEAKER CONNECTION. But first, this IMPORTANT note:

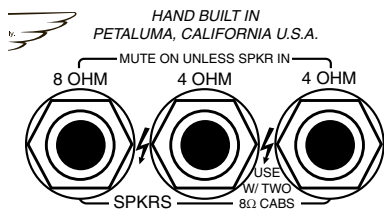

NOTE: IMPORTANT! MAKE SURE YOU HAVE A SPEAKER CONNECTED TO THE SPEAKER OUTPUT JACKS AT ALL TIMES! EVEN THOUGH THE PRODIGY HAS BUILT-IN PROTECTION, DON'T RELY ON THIS ALONE – IT IS A HIGH POWER AMPLIFIER AND

MUST HAVE A LOAD CONNECTED AT ALL TIMES!

NOTE: IMPORTANT! NEVER UNPLUG THE SPEAKER LOAD (Cabinet) WHILE THE AMPLIFIER IS IN USE AND BEING PLAYED!

The following are some basic Speaker Cabinet setup guidelines to follow for the proper loading, highest power headroom and tight, punchy Tone.

One 8 Ohm Cabinet should be connected to the 8 OHM SPEAKER OUTPUT.

Two 8 Ohm Cabinets should be connected to the two 4 OHM SPEAKER OUTPUTS.

One 4 Ohm Cabinet should be connected to one of the 4 OHM SPEAKER OUTPUTS.

The three wiring schemes above cover 90% of the Cabinet load scenarios you will encounter. If you are attempting to connect cabinets in a configuration not listed above, please consult the SPEAKER IMPEDANCE MATCHING AND HOOK-UP GUIDE toward the end of this manual. If you are still unsure of the proper connection, DO NOT GUESS – play it safe! The PRODIGY is a high power amplifier and improper speaker impedance connections can cause excessive tube wear or premature tube failure and other potentially expensive and time-consuming damages not covered under warranty due to misuse.

NOTE: IMPORTANT! DO NOT USE A 2 OHM LOAD ON THE PRODIGY. IT WILL CAUSE STRESS ON THE OUTPUT TRANSFORMER AND OUTPUT TUBES, CREATE EXCESSIVE HEAT AND WEAR THE POWER TUBES FASTER OR CAUSE THEM TO FAIL PREMATURELY.

REAR PANEL CONTROLS *(Continued)*

MULTI-WATT™ and SPEAKER OUTPUT CHOICES

NOTE: When switching between HALF and FULL POWER of the PRODIGY's MULTI-WATT™ options, the impedance changes slightly at the SPEAKER OUTPUT jacks. While you can't really damage the amplifier with an impedance mismatch (other than a 2 OHM load – NOT RECOMMENDED), the sound and feel of the amp can be either optimized or compromised (sometimes purposefully) by the intentional matching or mismatching of the Speaker Load.

When the PRODIGY is being used in the MULTI-WATT position of HALF POWER, the impedance of the SPEAKER OUTPUTS (as labeled on the rear panel) changes. Loosely, the SPEAKER OUTPUT impedances double – the 4 OHM jacks become 8 OHM each and the 8 OHM jack becomes a 16 OHM.

For example, if you have an 8 OHM cabinet, while in HALF POWER, try plugging it into one of the 4 OHM jacks for a proper impedance match. This will maximize the punch and output of the HALF POWER setting. However, if you leave the 8 OHM cabinet in the 8 OHM SPEAKER OUTPUT in HALF POWER, a slight roll-off of top end frequencies occurs as well as softening of the attack and a general warmer sound overall, due to the mismatch. Feel free to experiment but never mismatch a cabinet to the amp by more than one increment.

Each of the MULTI-WATT Power Choices can be shaped, colored and even placed “strategically” in the time domain by matching the Speaker Cabinet with the proper SPEAKER OUTPUT. While there really isn't a “wrong” combination, there are some Load combinations that sound better to most players (tighter, more focused and bolder) – than others. You will want to experiment with your Cabinets and the SPEAKER OUTPUTS to find what suits your style and sound the best. Below are some scenarios we like best:

FULL POWER – Follow the Guidelines above

HALF POWER - 8 Ohm Cabinet into one 4 OHM SPEAKER OUTPUT
4 Ohm Cabinet into the 4 OHM SPEAKER OUTPUT

SPEAKER OUTPUT AUTO-MUTE FUNCTION

Your PRODIGY has built-in Output Transformer protection against a No-Load scenario in the form of an AUTO-MUTE Circuit via switching built right into the SPEAKER OUTPUT jacks.

When the Speaker Cable is inserted to any one of the three SPEAKER OUTPUT jacks, the AUTO-MUTE circuit is bypassed and audio signal is allowed to pass and power your speakers. However, this does not mean that you should throw common sense to the wind and depend solely on this circuit to care for your amplifier as you still need to make sure the other end of your cable is plugged into the cabinet (the AUTO-MUTE circuit does NOT protect against this scenario). As with any amplifier with an all-tube Output Section – ALWAYS MAKE SURE THERE IS A SPEAKER CONNECTED TO YOUR SPEAKER OUTPUTS.

The PRODIGY is a high power amplifier with very high current running through the Power Tubes and Output Transformer. Sending a signal through it without a Load (Speaker Cabinet or other adequate Load) connected would almost certainly damage the Output Transformer and Power Tubes and is NOT covered under warranty.

The AUTO-MUTE Circuit was designed primarily to avoid accidental no-load conditions but it is VERY IMPORTANT for YOU to be vigilant and get in the habit of checking your SPEAKER OUTPUTS every time you play and anytime you hear no sound when you expect you should. BEFORE you flip the POWER – and definitely the STANDBY switches, always confirm that a speaker load is present by confirming the connection at your cabinet AND the amp.

NOTE: When there is nothing plugged into the SPEAKER OUTPUTS the front panel MUTE LED will be ON. This is an indicator that there is No Load connected.

NOTE: IMPORTANT! MAKE SURE YOU HAVE A SPEAKER CONNECTED TO THE SPEAKER OUTPUT JACKS AT ALL TIMES!

NOTE: IMPORTANT! NEVER UNPLUG THE SPEAKER LOAD (Cabinet) WHILE THE AMPLIFIER IS IN USE (being played)

D.I. OUTPUT

This 3-pin male XLR handles the interface connection between the D.I. OUTPUT (Direct Out) of the PRODIGY to Live Consoles or Recording Devices. Depending on the setting of the Front Panel D.I. SELECT mini toggle, the D.I. OUTPUT captures either the unaffected, direct sound of your instrument when PRE is selected – or – when POST is selected, the signal consists of the instrument AND the all-tube preamp, Tone Controls, VOICE selections and Processing in the EFFECTS LOOP. Both PRE and POST D.I. selections produce a “balanced” signal at the XLR D.I. OUTPUT, so longer cable lengths will not affect your sound due to increased cable capacitance.

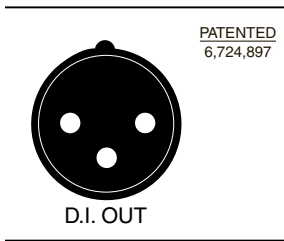

The signal strength present at the D.I. OUTPUT is affected by all the settings on your preamp (in the D.I. POST Position). However, the final output level that appears at the D.I. OUTPUT jack is set by the D.I. OUTPUT control on the Front Panel. The overall range of signal available is optimized for Console interfacing and you will likely find a setting of 12:00 noon provides a good nominal signal strength that is in the ball park for most Consoles. It's a good habit to ZERO your D.I. OUTPUT control before plugging into a console or recording device and roll the D.I. LEVEL up slowly once signal can be monitored. Should you need more or less signal, the range of the Front Panel D.I. LEVEL offers increments in both directions.

NOTE: The D.I. OUTPUT will have signal present when in the PRE selection even when STANDBY is used to mute the signal to the power section (STANDBY position) as this is the direct signal straight from your instrument before it goes through the amplifier.

REST AREA

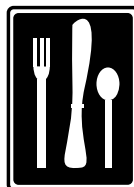
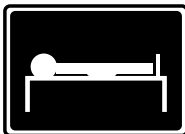

FACTORY SAMPLE SETTINGS

SAMPLE #1: Warm R&B

BRIGHT NORMAL INPUT A ELECTRIC
 GAIN BASS MID TREBLE VOICE MASTER
 MUTE SIL. REC. PLAY HALF PWR
BASS PRODIGY
 TUBE POWER™
 DI PRE POST DI LIFT GROUND
 DI LEVEL SOLO
 POWER ON
 STANDBY ON
Four:88

SAMPLE #2: Motown Round

BRIGHT NORMAL INPUT A ELECTRIC
 GAIN BASS MID TREBLE VOICE MASTER
 MUTE SIL. REC. PLAY HALF PWR
BASS PRODIGY
 TUBE POWER™
 DI PRE POST DI LIFT GROUND
 DI LEVEL SOLO
 POWER ON
 STANDBY ON
Four:88

SAMPLE #3: Classic Rock Bass

BRIGHT NORMAL INPUT A ELECTRIC
 GAIN BASS MID TREBLE VOICE MASTER
 MUTE SIL. REC. PLAY HALF PWR
BASS PRODIGY
 TUBE POWER™
 DI PRE POST DI LIFT GROUND
 DI LEVEL SOLO
 POWER ON
 STANDBY ON
Four:88

SAMPLE #4: Rock Growl

BRIGHT NORMAL INPUT A ELECTRIC
 GAIN BASS MID TREBLE VOICE MASTER
 MUTE SIL. REC. PLAY FULL HALF PWR
BASS PRODIGY
 TUBE POWER™
 DI PRE POST DI LIFT GROUND
 DI LEVEL SOLO
 POWER ON
 STANDBY ON
Four:88

SAMPLE #5: Fat Thumb

BRIGHT NORMAL INPUT A ELECTRIC
 GAIN BASS MID TREBLE VOICE MASTER
 MUTE SIL. REC. PLAY HALF PWR
BASS PRODIGY
 TUBE POWER™
 DI PRE POST DI LIFT GROUND
 DI LEVEL SOLO
 POWER ON
 STANDBY ON
Four:88

SAMPLE #6: Mid Staccato

BRIGHT NORMAL INPUT A ELECTRIC
 GAIN BASS MID TREBLE VOICE MASTER
 MUTE SIL. REC. PLAY FULL HALF PWR
BASS PRODIGY
 TUBE POWER™
 DI PRE POST DI LIFT GROUND
 DI LEVEL SOLO
 POWER ON
 STANDBY ON
Four:88

PERSONAL SETTINGS SHEET

Control panel diagram for Bass Prodigy Tube Power Four:88 amplifier. The panel includes the following controls from left to right: a vertical input selector with positions for NORMAL, VINTAGE, and INPUT; a GAIN knob; a BASS knob; a MID knob; a TREBLE knob; a VOICE knob with positions 1, 2, 3, 4, and .5; a MASTER knob; a vertical power selector with positions for PLAY, MUTE, FULL, and HALF PWR; the Bass Prodigy Tube Power logo; a vertical DI selector with positions for DI PRE, POST, DI LIFT, and GROUND; a DI LEVEL knob; a SOLO knob; and two rotary switches for POWER and STANDBY, each with ON and OFF positions. The brand name Four:88 is printed at the bottom right.

Control panel diagram for Bass Prodigy Tube Power Four:88 amplifier. The panel includes the following controls from left to right: a vertical input selector with positions for NORMAL, VINTAGE, and INPUT; a GAIN knob; a BASS knob; a MID knob; a TREBLE knob; a VOICE knob with positions 1, 2, 3, 4, and .5; a MASTER knob; a vertical power selector with positions for PLAY, MUTE, FULL, and HALF PWR; the Bass Prodigy Tube Power logo; a vertical DI selector with positions for DI PRE, POST, DI LIFT, and GROUND; a DI LEVEL knob; a SOLO knob; and two rotary switches for POWER and STANDBY, each with ON and OFF positions. The brand name Four:88 is printed at the bottom right.

Control panel diagram for Bass Prodigy Tube Power Four:88 amplifier. The panel includes the following controls from left to right: a vertical input selector with positions for NORMAL, VINTAGE, and INPUT; a GAIN knob; a BASS knob; a MID knob; a TREBLE knob; a VOICE knob with positions 1, 2, 3, 4, and .5; a MASTER knob; a vertical power selector with positions for PLAY, MUTE, FULL, and HALF PWR; the Bass Prodigy Tube Power logo; a vertical DI selector with positions for DI PRE, POST, DI LIFT, and GROUND; a DI LEVEL knob; a SOLO knob; and two rotary switches for POWER and STANDBY, each with ON and OFF positions. The brand name Four:88 is printed at the bottom right.

Control panel diagram for Bass Prodigy Tube Power Four:88 amplifier. The panel includes the following controls from left to right: a vertical input selector with positions for NORMAL, VINTAGE, and INPUT; a GAIN knob; a BASS knob; a MID knob; a TREBLE knob; a VOICE knob with positions 1, 2, 3, 4, and .5; a MASTER knob; a vertical power selector with positions for PLAY, MUTE, FULL, and HALF PWR; the Bass Prodigy Tube Power logo; a vertical DI selector with positions for DI PRE, POST, DI LIFT, and GROUND; a DI LEVEL knob; a SOLO knob; and two rotary switches for POWER and STANDBY, each with ON and OFF positions. The brand name Four:88 is printed at the bottom right.

BIASING THE KT88 POWER TUBES – by Designer Randall Smith

First and foremost: Bias adjustment is only **required** when **replacing** power tubes. Checking bias as routine maintenance or if a tube problem is suspected is quick and easy but shouldn't often be necessary. And since those big KT88s in your amplifier are only running about half their maximum rated dissipation, they should last for years.

Nevertheless, we have provided a simple and effective bias adjust system that you can use yourself with only a little care and a small screwdriver. This deviates from our standard practice for 6L6s over the last 40 years where the bias is fixed to the "sweet spot" as each amp is built. Why this difference?

First, a little history: Traditional Fender 6L6 amp schematics show the bias setting to be -52 volts. What ISN'T specified are some important factors, such as the AC mains voltage which can vary up to 14% and affects the bias setting equally.

But most important is: What is the desired Plate Current that the power tubes should be biased to draw? Because getting that current set right is the whole point of adjusting the bias. And here's where the going gets tougher. Fender offered no spec for plate current, probably because measuring current (the "amount" of electricity flowing) is difficult. Properly done, it requires cutting the wire leading to the output transformer and inserting an amp meter in series with that current path. And plate current in a tube amplifier runs at high voltage, around 400 to 500 volts for 6L6s and much higher for our KT88s. Unless you're a technician and REALLY know what you're doing inside an amplifier... you don't want to mess with that.

Obviously Fender's adjustable system and our individually hard-wired systems both work – though in my many years of servicing Fenders, the bias settings were often found to be far from "correct". And with the wide availability of quality 6L6 tubes, especially our own selected MESA tubes, adjustments outside our designer's "sweet spot" are unnecessary and usually undesirable (unless you like paying a tech to re-set your amp's bias voltage.)

But KT88s are different and sampling them from various suppliers revealed a far greater variation in plate current for any given bias voltage compared to 6L6s. And with the 88's greater size and capacity, the current draw varied from 15mA (milli-amperes) to 50 mA whereas our "sweet spot" was 30 mA. So... we've provided a simple, safe system for bias adjustment that actually measures the current flowing through the tubes, not just some standard bias voltage. Use MESA Matched Tubes whenever possible in your amplifier and you will find they are far closer to the specified range than those available elsewhere. Because of this you will save yourself time and ensure your amplifier's Tone will stay intact as the BIAS setting is a critical element in its performance.

BIAS ADJUST: OPERATE / SET BIAS

NOTE: *The optimum BIAS SETTING was arrived at through EXTENSIVE scrutiny during the development of your amplifier. We STRONGLY RECOMMEND adhering to the Suggested Optimum Factory Setting for both Tonal and Reliability reasons. MESA has historically avoided Adjustable Bias Controls on our amplifiers for one important reason; the average musician has neither the training nor equipment to properly adjust the Bias in their amplifier. We see too many examples of this in our Authorized Repair Stations in the field and in our Repair Department here at the Factory to believe otherwise. The Internet is full of people espousing the virtues of a (too) high Bias Setting. Don't Be Fooled!*

The Recommended Bias Setting your amplifier was shipped with delivers the absolute best blend of Tone and Reliability. This has been confirmed time and again throughout the entire course of its development. Please – Do Yourself A Favor – Don't Mess With The Bias Looking For "Better Tone". It's not there.

NOTE: IMPORTANT! *Adjust the Bias only when replacing Power Tubes and Adhere to the Owner Achievable Bias Setting Described! FAILURE TO ADHERE TO THE RECOMMENDED FACTORY BIAS SETTING WILL VOID YOUR WARRANTY, WEAR YOUR POWER TUBES FASTER AND COULD CAUSE DAMAGE TO YOUR AMPLIFIER!*

Owners - it is not necessary to remove the Bottom Cover on your PRODIGY to set the BIAS when replacing Power Tubes. Located on top of the chassis is a 2-position mini-toggle switch, along side a precision Trim Pot and an LED. The BIAS ADJUST circuit allows for precise setting of the Bias for the Technician using a Current Meter - or - a “near perfect” setting of the Bias for the not-so-technically-minded Musician/Owner with a very small “flathead” screwdriver. Owners and non-technicians can adjust their Bias when re-tubing by setting the BIAS ADJUST Switch to SET BIAS and following the Bias Adjustment Instructions below.

Like some other amplifiers, this system measures current at the cathodes which, with no signal running through the amp, is the same as plate current (plus the minute screen current). But unlike other systems, the BIAS ADJUST switch entirely removes the adjustment circuit and its cathode resistors from the audio chain when adjustment is complete and it is set back to OPERATE.

OPERATE: This position is for playing your amplifier. The BIAS ADJUST switch should be set here at all times unless you are adjusting the BIAS after replacing a worn set of power tubes.

Technicians – you know what to do. Set BIAS ADJUST SWITCH to SET BIAS Position - Check and Adjust Cathode Current: Set to 120 – 125 mA.

This Bias Adjust Mode also allows for a near-perfect Owner Achievable Bias Setting with nothing more than a small jewelers flat-head screwdriver. Again – adhere to the directions below and adjust your Bias ONLY after replacing worn power tubes with a new set.

NOTE: When the Bias switch is in the Set Bias position, the Mute LED will be on and the amp will be muted. This is to prevent the amp from passing signal while the Bias circuit is engaged.

Owners – the following simple procedure is also printed on the chassis top (Tube Deck) and consists of the following steps:

SET BIAS (For Non-Technicians)

1. Set the BIAS SWITCH (located on the upper Rear Tube Deck) to OPERATE. Make sure the amp is set to FULL POWER—setting the Bias while in HALF POWER will give an incorrect measurement.
2. Follow the Cold-Start Procedure under POWER in the Front Panel Section of this manual and Switch the PRODIGY to STANDBY ON after three minutes. Then allow the amp to warm up for another 5 minutes (POWER and STANDBY ON).
3. Set the BIAS SWITCH to SET BIAS. The MUTE circuit is activated by this setting and you may proceed with the procedure with no load connected to the SPEAKER OUTPUTS. BUT DON'T FORGET TO CONNECT A LOAD when you are finished with the BIAS setting procedure!
4. Using a small flat screwdriver, twist the trimmer pot counter-clockwise until the LED just goes dark... then:
5. Twist the trimmer EXACTLY ONE HALF turn clockwise toward greater brightness – Stop there. You're Done!
6. Set the BIAS ADJUST switch back to OPERATE and Play! Your BIAS is set for optimum performance and Tone. CHECK YOUR SPEAKER OUTPUTS! Don't forget to connect a load (cabinet) BEFORE playing!

NOTE: IMPORTANT! It is important when re-tubing your PRODIGY, to make sure that all the power tubes are matched to each other. This is critical to achieving a proper Bias Setting and also for obtaining the best performance from your amplifier. If your local dealer doesn't have a complete set of identically matched KT88s (Preferably MESA Tubes), you may order perfectly matched sets direct from us at www.mesaboogie.com or, by calling 707-778-6565 and asking for a Product Specialist - who will be happy to assist you with your purchase of these matched sets of KT88 Power Tubes.

NOTE! Original PRODIGY OWNERS! MESA offers a HALF-PRICE DISCOUNT on your FIRST SET of Replacement Power Tubes. This can be obtained by ORDERING DIRECT FROM THE FACTORY ONLY and the order must be accompanied by your ORIGINAL SALES RECEIPT as proof of ownership.

SPEAKER IMPEDANCE MATCHING & HOOK-UP GUIDE:

IMPEDANCE: Wiring up speakers to provide the most effective load and making sure that all of them are in phase will help in creating the best sound possible. This is not too difficult, as long as you understand a few things about loading and how to connect your speakers to provide an optimal resistive load.

MESA/Boogie amplifiers can handle 4 and 8 ohms effectively. Never run below 4 ohms in a tube amplifier unless you are absolutely certain that the system can handle it properly; this can cause damage to the Output transformer. A few amplifiers can handle 2 ohms effectively without damaging them (for example the MESA'S Bass 400+). You can always have a higher resistance (16 ohms, for example) without damaging results, but too low of a resistance will likely cause problems.

MIS-MATCHING: When running a higher resistance (for example: 8 ohm output into 16 ohm cabinet), a slightly different feel and response will be eminent. A slight mismatch can provide a darker smoother tone with a little less output and attack. This response is a result of the amplifier running a bit cooler. Sometimes when using more than one cabinet a mismatch will be the only option.

WHAT IS MY CABINETS IMPEDANCE: If you have only a single speaker, you just match that single speakers impedance to the amplifier, and you are done. In many cases, you will have a number of speakers, and then you must calculate the "load" that the amplifier will need to support. There are generally three ways to wire multiple speakers together. They are as follows:

SERIES: When you wire (hook-up) speakers in Series, the speakers resistance (as measured in ohms) is additive - i.e. putting two 8 ohm speakers in Series results in a 16 ohm load.

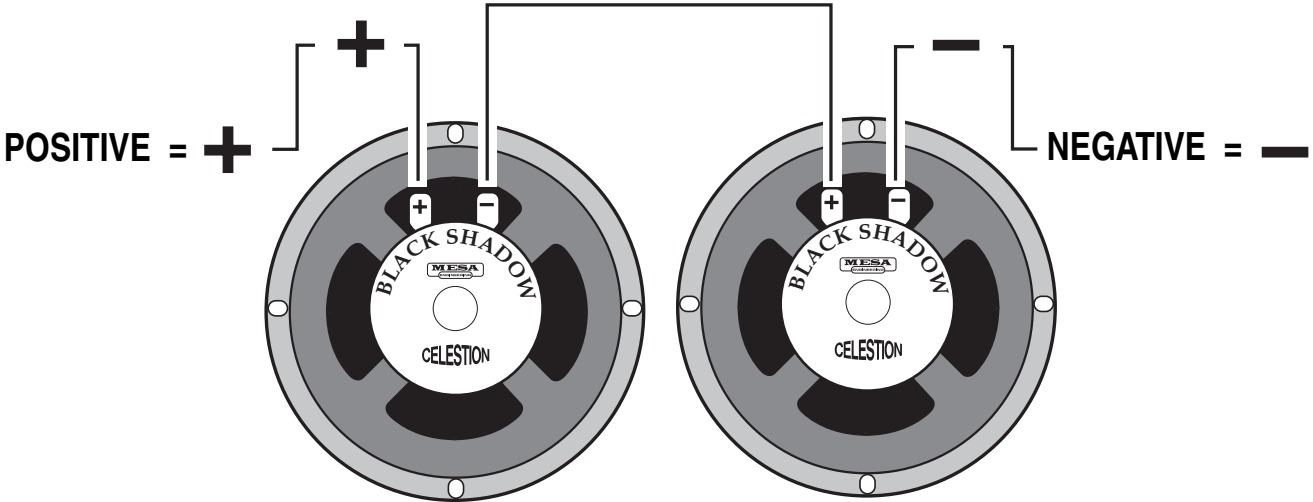

Speaker A = 8 Ohms Speaker B = 8 Ohms
SERIES: Connect the Negative side of Speaker A to the Positive side of Speaker B

PARALLEL: When wiring in parallel, the resistance of the speakers decreases. Two 8 ohm speakers wired in (hooked-up) Parallel results in a 4 ohm load. It's easy to calculate the effect of a resistive load when all the speakers are all the same resistance. It is really not suggested to wire different resistive load values in Parallel (8 and 4, 16 and 8 etc.) The formula for figuring the total impedance in Parallel is the multiplication of the two loads divided by the sum of the two loads - i.e. putting two 8 ohm speakers in Parallel results in a 4 ohm load. Connect the Positive side of Speaker A to the Positive side of Speaker B - Connect the Negative side of Speaker A to the Negative side of Speaker B.

COMBINATION OF SERIES & PARALLEL: This is really just two sets of Series wired speakers connected in Parallel. This is how you maintain a consistent load with multiple speakers. The importance of this is more evident when you have more than one

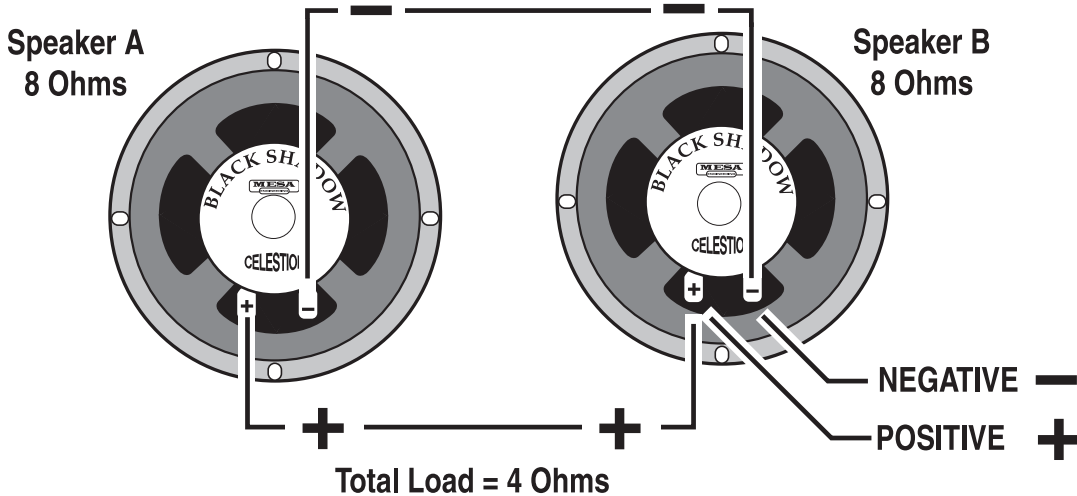

cabinet to connect to your amplifier. This is when you need to figure out the loads and how to wire them up without applying too low of a resistance on the amplifier.

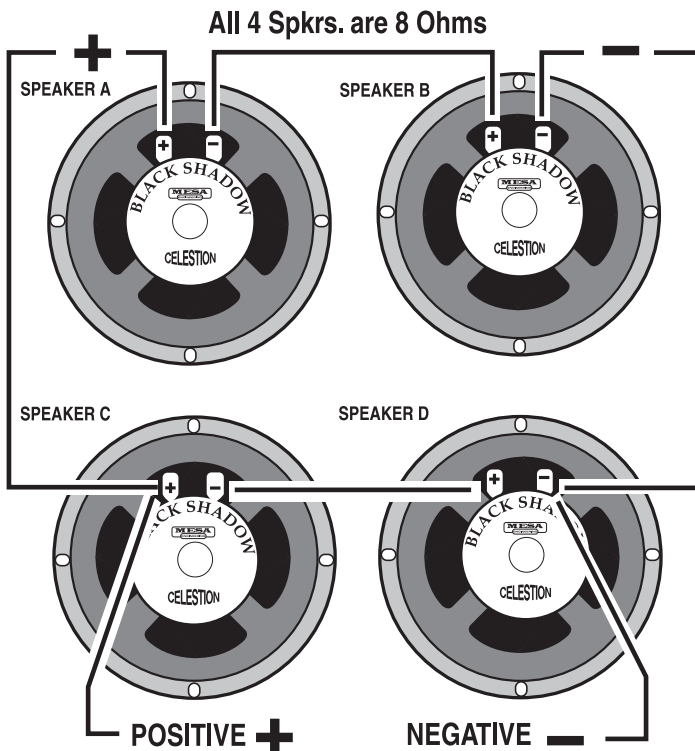

Simply connect the Positive side of Speaker A to the Positive side of Speaker C.

Connect the Negative side of Speaker A to the Positive side of Speaker B. Next, connect the Negative side of Speaker C to the Positive side of Speaker D.

And lastly, connect the Negative side of Speaker B to the Negative side of Speaker D.

4 Eight (8) Ohm speakers wired in Series Parallel = a Total Load of 8 Ohms.

1

WIRING SCHEMES...Amplifier to Speaker Cabinets

2

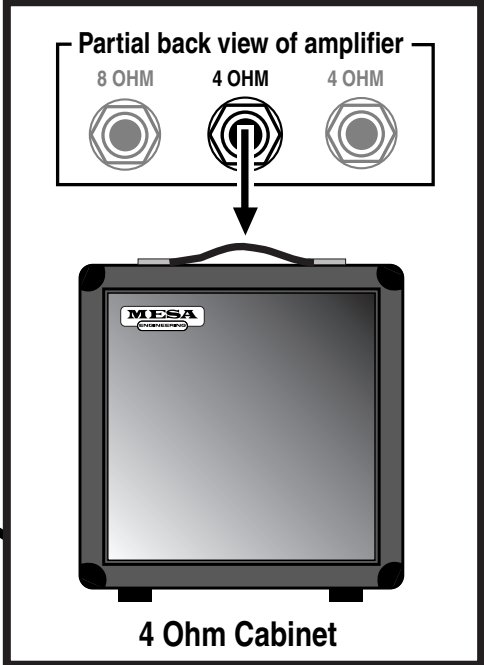
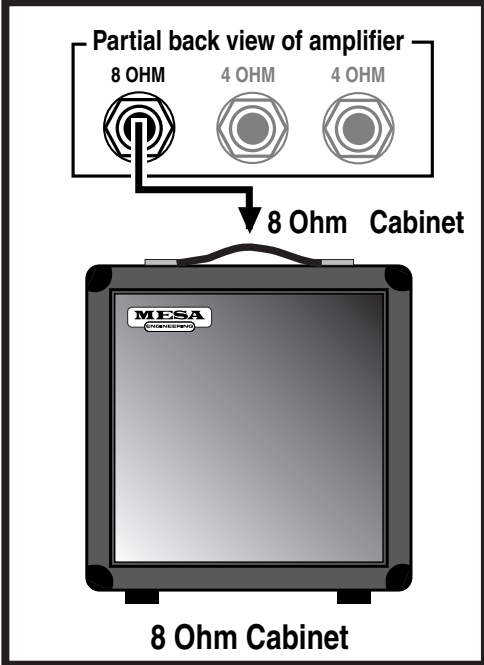

3

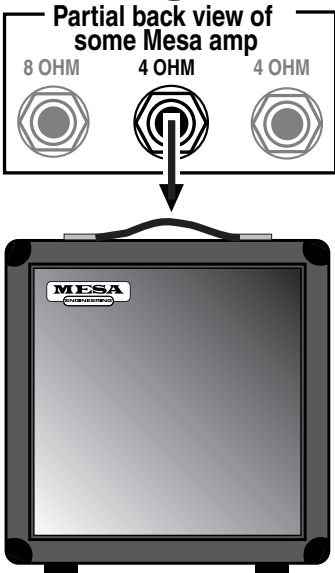

4

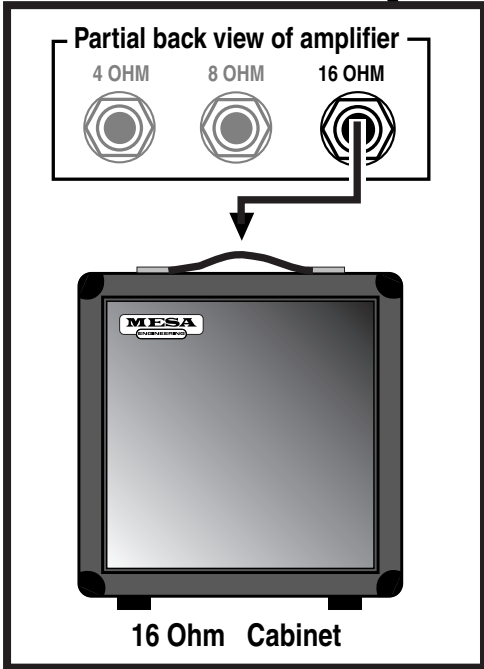

5

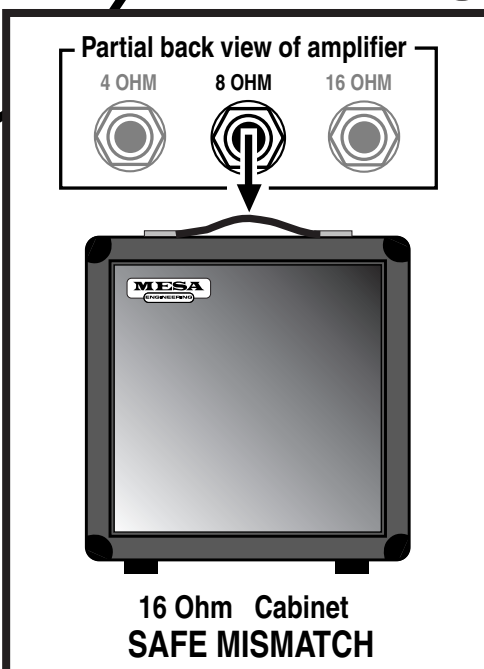

WIRING SCHEMES...Amplifier to Speaker Cabinets

6

7

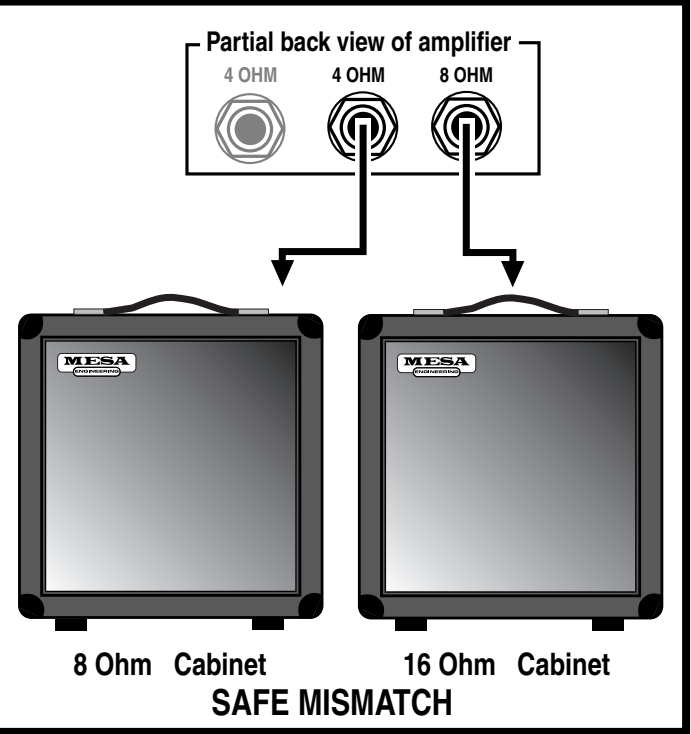
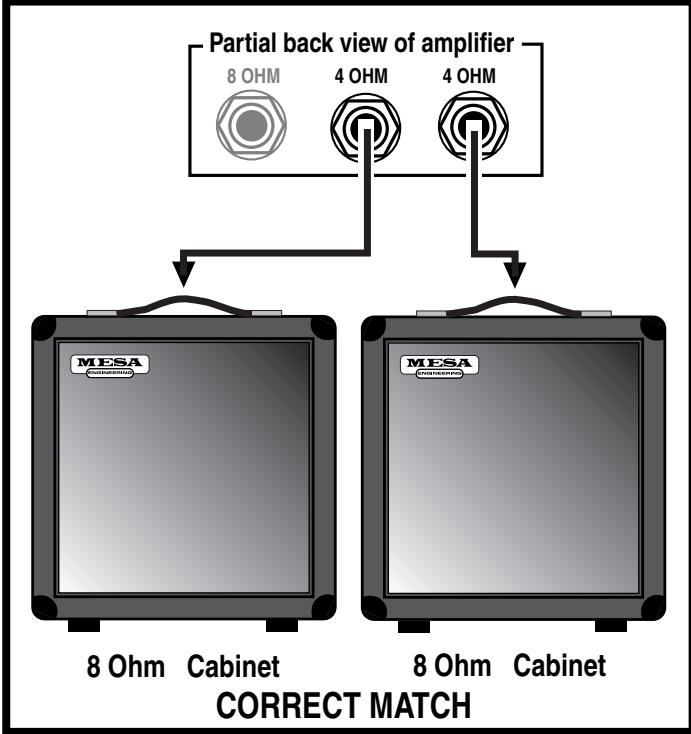

8

9

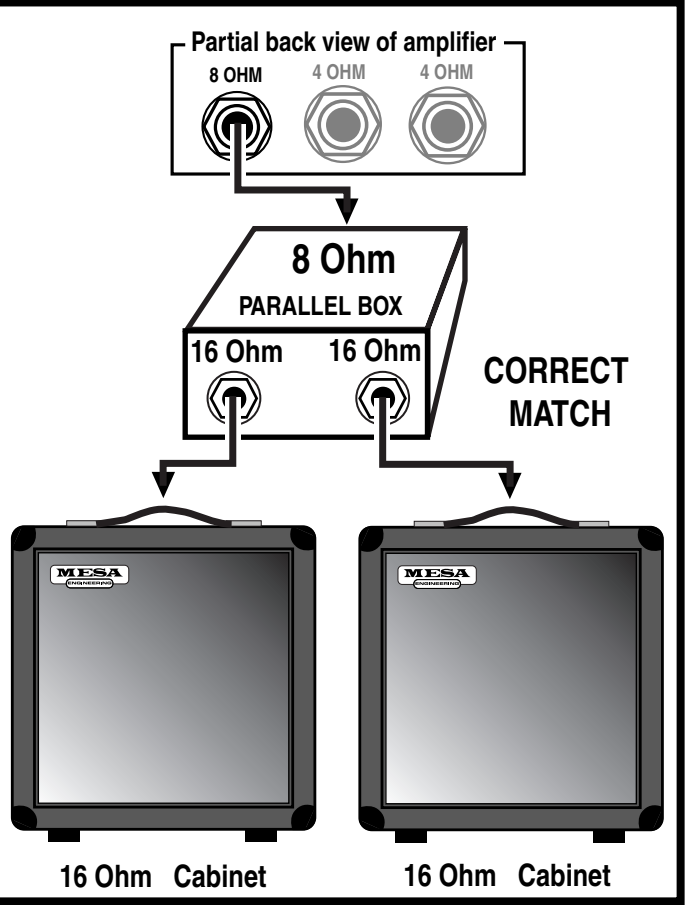
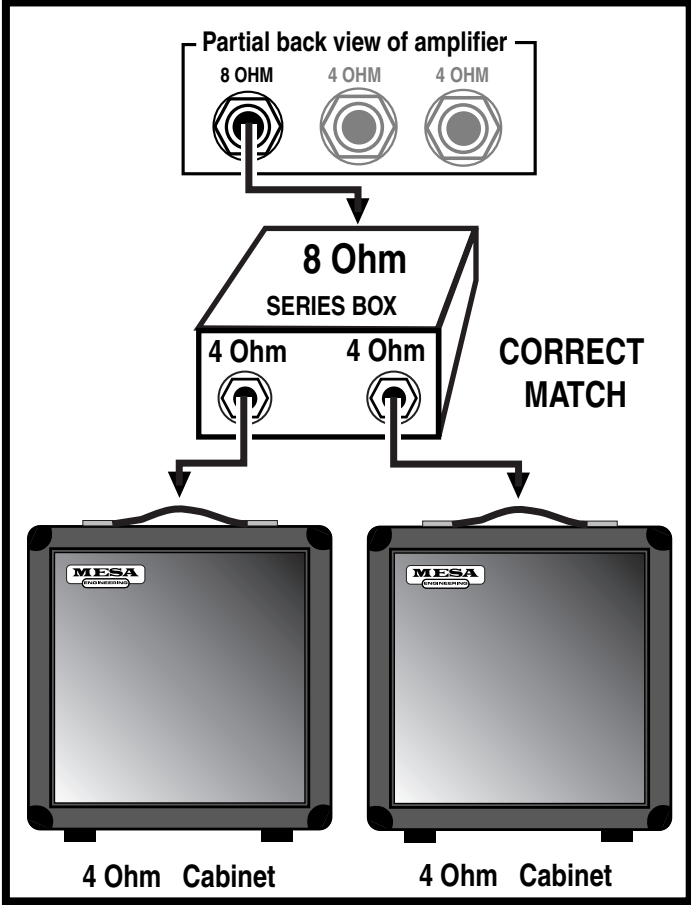

WIRING SCHEMES...Amplifier to Speaker Cabinets

10

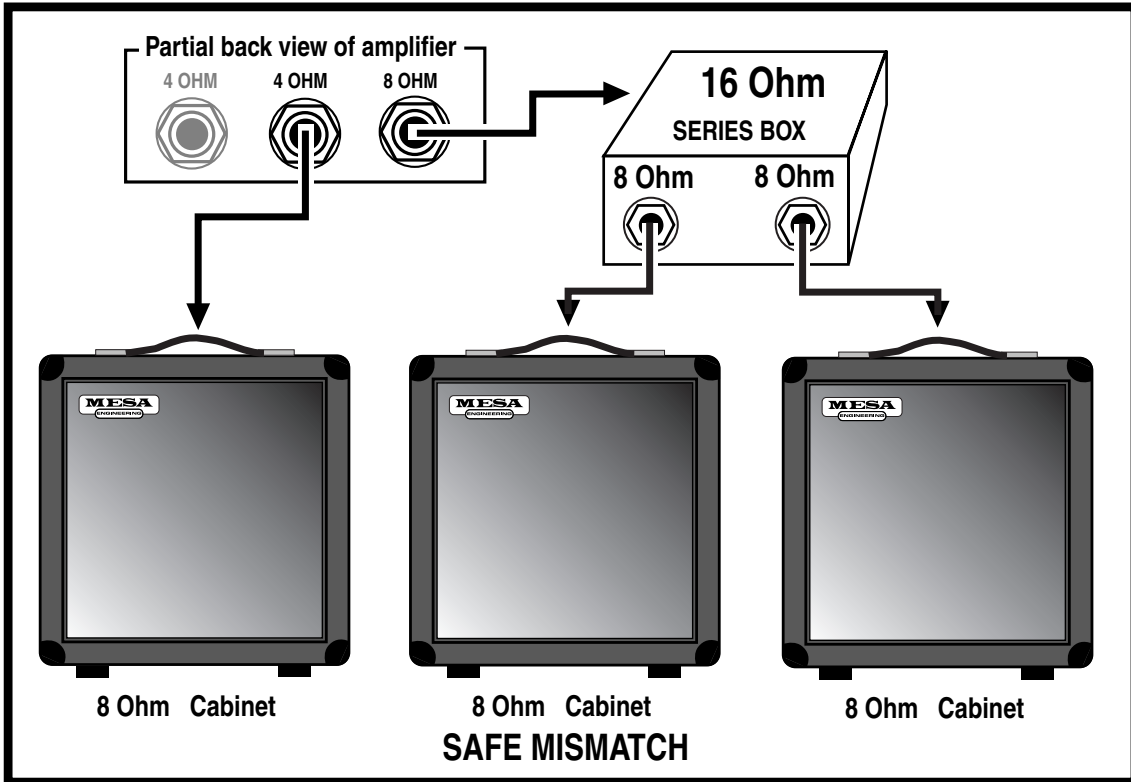

11

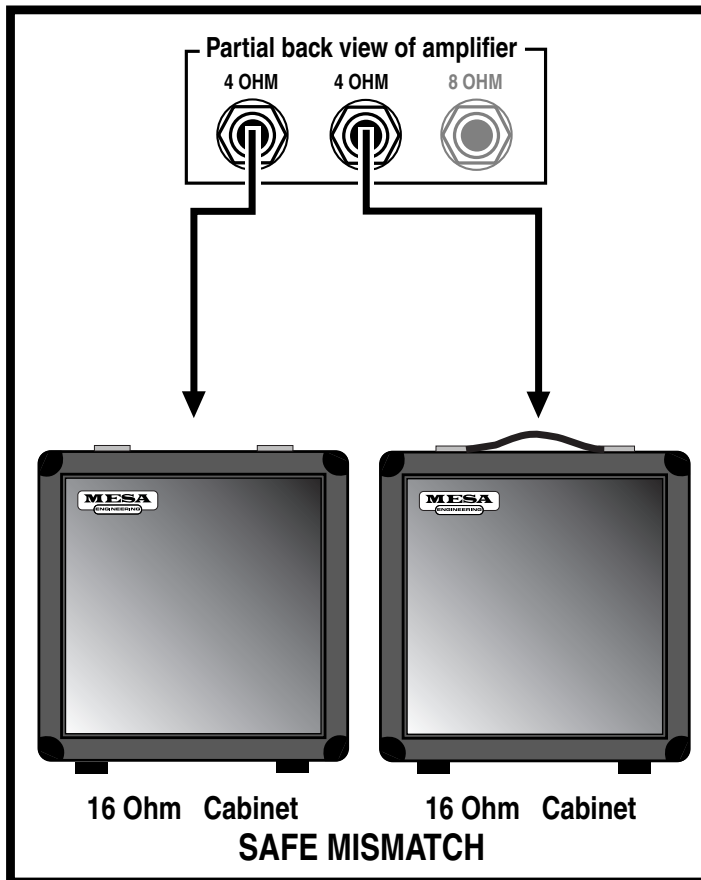

12

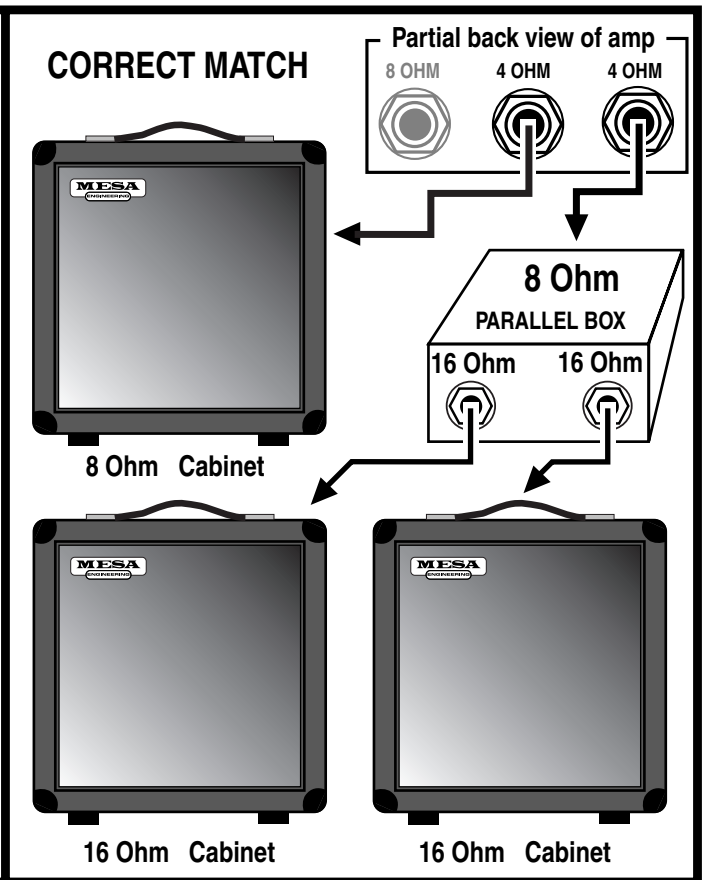

WIRING SCHEMES...Amplifier to Speaker Cabinets

13

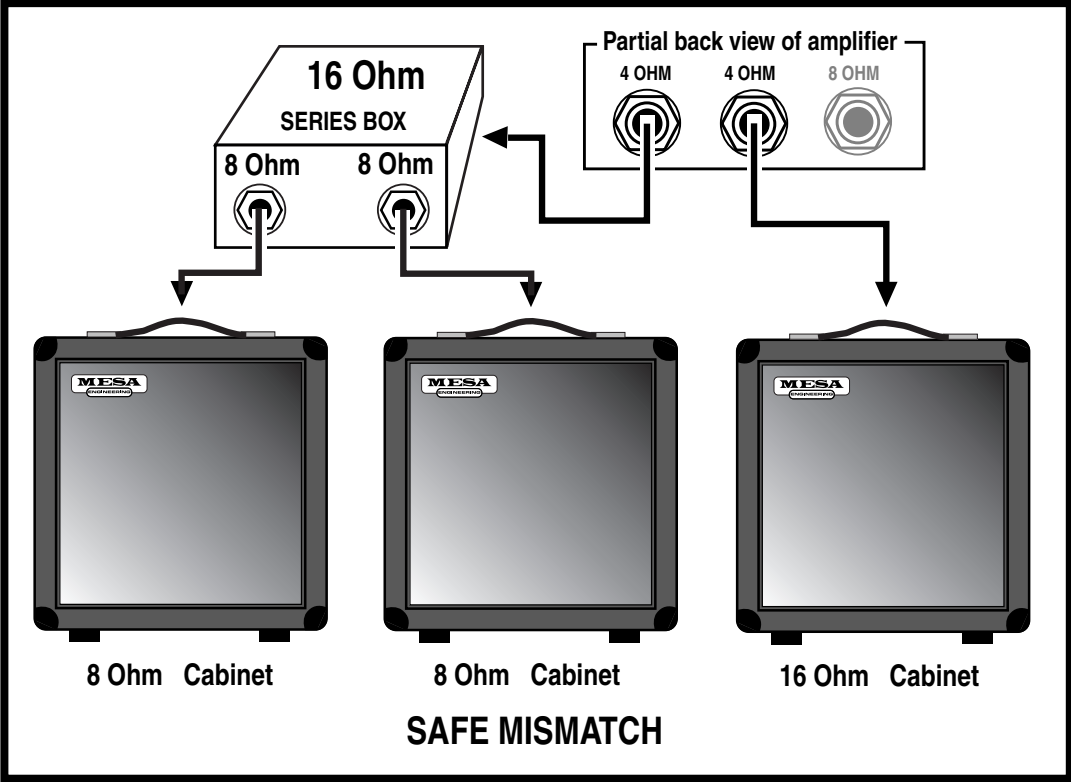

14

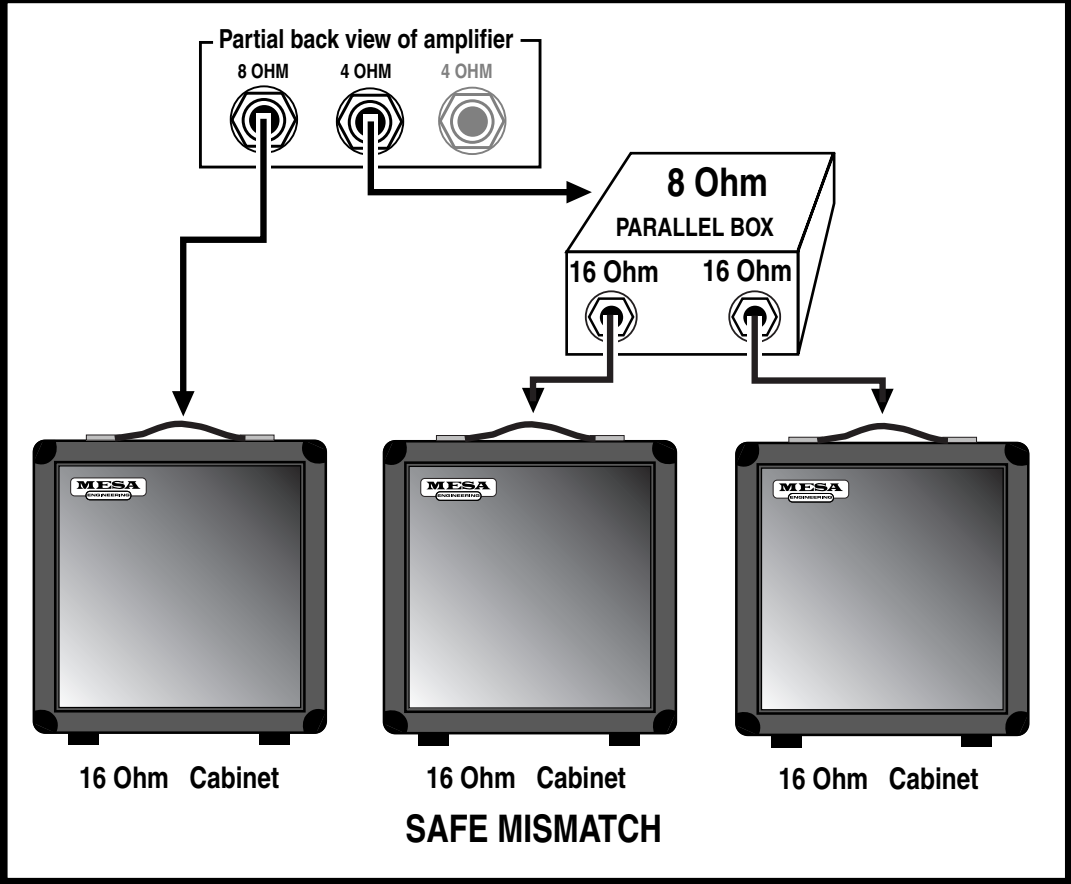

TUBE NOISE & MICROPHONICS:

You may occasionally experience some form of tube noise or microphonics. Certainly no cause for alarm, this quirky behavior comes with the territory and the Tone. Much like changing a light bulb, you don't need a technician to cure these types of minor user serviceable annoyances and in fact, you'll be amazed at how easy it is to cure tube problems...by simply swapping out a pre-amp or power tube!

First may we suggest that you set the amplifier up on something so that you can get to the tubes comfortably without having to bend down. It also helps to have adequate lighting as you will need to see the tube sockets clearly to swap tubes. Use caution and common sense when touching the tubes after the amplifier has been on as they may be extremely hot! If they are hot and you don't want to wait for them to cool off, try grasping them with a rag and also note that the glass down around the bulbous silvery tip is considerably less hot which makes it easier to handle. Gently rock the tube back and forth as you pull it away from its socket.

TUBE NOISE:

Often caused by contamination within in a tube, the culprit can usually be identified, and by lightly tapping on the glass, you will probably hear the noise change. Hearing some noise through the speakers while tapping on the 12AX7's is normal however. And the one nearer the INPUT will always sound louder because its output is being further amplified by the second 12AX7.

The power tubes should be all but quiet when they are tapped. If crackling or hissing changes with the tapping, you have probably found the problem. To confirm a noisy power tube, merely put the amplifier on Standby, remove it from its socket and turn it back on. It will cause no damage to run the amplifier briefly with one power tube missing. You may notice a slight background hum, however, as the push-pull becomes unbalanced. Whenever you are trying to diagnose a suspect tube, keep your other hand on the POWER and STANDBY switches ready to shut them off instantly in the unlikely case you provoke a major short.

If you think you've located a problem tube but aren't sure, we recommend substituting the suspect with a new one just to be sure of your diagnoses. You will be doing yourself and us a big favor by just following the simple guidelines previously mentioned regarding tube replacement. You'll probably be successful with much less effort than is required to disconnect everything and haul the unit to a technician who will basically perform the same simple tests. If the tubes are still within their six-month warranty period, we will happily send you a replacement. Just note the color designation on the tube label so that we can send you the appropriate match.

DIAGNOSING PRE-AMP TUBE PROBLEMS:

Because your amplifier is an all tube design, it is quite possible that you will at some point experience minor pre-amp tube noise. Rest assured - this is no cause for alarm and you can take care of the problem yourself in a matter of minutes by simply swapping tubes.

Let us begin by saying; It is a "very good" idea to keep at least a couple of spare pre-amp tubes on hand at all times to insure uninterrupted performance. These minor pre-amp tube problems can take many forms but can generally be described in two categories: Noise and Microphonics. Noise can be in the form of crackling, sputtering, white noise/hiss and/or hum. Microphonic problems usually appear in the form of a ringing or high pitched squealing that gets worse as the gain or volume is increased thus are more noticeable in the higher gain "HI" modes. Microphonic problems are easily identified because the problem is still present even with the instruments' volume off or unplugged altogether - unlike pick-up feedback which ceases as the instrument is turned down. Microphonic noise is caused by mechanical vibration and shock: think of banging a microphone around and you'll understand where the word came from.

The best way to approach a pre-amp tube problem is to see if it occurs only in one specific mode or channel. This should lead you to the tube needing replacement. Then all that remains is to swap the suspect tube for a known good performer. If you cannot narrow down the trouble to a specific mode or channel, the problem may be the small tube that drives the power tubes which is operational in all modes and channels. Though rare, a problem with the driver tube would show up in all aspects of performance - so if you can't narrow the problem down to being mode or channel specific, you may want to try replacing the driver tube. Driver problems generally show themselves in the form of crackling or hum in all modes of performance and/or weak overall output from the amplifier. Occasionally an anemic driver tube will cause the amplifier to sound flat and lifeless, but this is somewhat uncommon, as worn power tubes are a more likely suspect for this type of problem.

Sometimes making the diagnosis is more trouble than it's worth and it's faster and easier to merely replace the small pre-amp tubes ONE AT A TIME with a replacement known to be good. But MAKE SURE you keep returning the tubes to their original socket until you hit the one that cures the problem. You'll notice that tubes located nearer to the INPUT jack always sound noisier...but this is because they are at the start of the chain and their noise gets amplified over and over by the tubes that follow. The tube that goes into this "input socket" (usually labeled V1) needs to be the least noisy of the bunch. The tube that goes at the end of the preamp chain - just ahead of the power tubes - can be quite noisy without causing any problem at all. The tubes in your amp have already been located in the most appropriate sockets and this is why you should NEVER pull them all out at once and ALWAYS swap them one at a time. ALWAYS return a perfectly good tube to its original socket. Also it's a good idea to put the amp on STANDBY when swapping tubes to reduce the heat build up in the tubes themselves and to prevent explosive noises (which can still occur even if you are pulling the tubes away from their sockets gently) from coming through the speaker.

Remember, take your time, be patient and chances are real good that you can fix your amp yourself by finding and replacing the bad tube. It kills us to see someone who has shipped their amp back to us...and all it needed was a simple tube replacement! If you must send back your amp, remove the chassis from the cabinet by unscrewing the four mounting bolts on the bottom top. The chassis then slides back like a drawer and comes out from the back. Remove the big power tubes and mark them according to their location from left to right 1, 2 etc. They need to be wrapped separately with plenty of wadded up newspaper around them and put in a smaller box within the larger carton. Remove the Rectifier tubes and wrap them also. You can leave the preamp tubes in or remove them and wrap them separately being sure to label their location. (See Tube Task Chart.)

To wrap the chassis, use plenty of tightly wadded up newspaper so there is at least six inches of "crush space" between the chassis and the cardboard box. Bubble wrap also works well, but please DON'T use styrene peanuts - they will shift during transit and get lodged inside your electronics as well as allowing your amp to end up at the bottom of the box unprotected and possibly damaged.

Pre-amp tubes don't normally wear out as a rule. Therefore, it is not a good idea to change them just for the sake of changing them. If there isn't a problem - don't fix it. If there is no result from your substitutions, it may be possible that you have more than one problematic tube. Though rare, this does happen and though it makes the troubleshooting process a little more intimidating, it is still possible to cure the problem yourself.

NOTE: It is normal to hear a slight metallic ringing sound when tapping on the preamp tubes. As long as the tube does not break into oscillation or start crackling or any other form of bizarre noise, it is considered normal and functional.

DIAGNOSING POWER TUBE FAILURE:

There are two main types of tube faults: shorts and noise. Both large and small tubes may fall prey to either of these problems but diagnosis and remedy is usually simple.

If a fuse blows, the problem is most likely a shorted power tube and shorts can either be mild or severe. In a mildly shorted tube the electron flow has overcome the control grid and excess current flows to the plate. You will usually hear the amp become distorted and begin to hum slightly. If this occurs, quickly look at the power tubes as you switch the amp to STANDBY and try to identify one as glowing red hot. It is likely that two of a pair will be glowing since the "shorted" tube will pull down the bias for its adjacent mates, but one tube may be glowing hotter — and that one is the culprit. The other two are often fine — unless they've been glowing bright red for several minutes.

Because there is no physical short inside the tube (just electrons rioting out of control) merely switching to STANDBY for a few moments then back to ON will usually cure the problem...at least temporarily. Watch the tubes carefully now. Should the problem recur, the intermittent tube will visibly start to over heat before the others and thus it can be identified. It should be replaced with one from the same color batch, shown on its label. Call us and we will send one out to you.

The severe short is not nearly so benign. In the worst cases, a major arcing short occurs between the plate and the cathode with visible lightning inside the glass and a major noise through the speaker. If this is seen to happen, IMMEDIATELY turn the amp to STANDBY. By this time the fuse probably will have blown. Such a short is usually caused by a physical breakdown inside the tube including contaminate coming loose or physical contact (or near contact) between the elements. Replace it and the fuse with the proper slo-blo type and power up the amp using the power up procedure as we described earlier in this manual.

BEFORE CHANGING TUBES FLIP POWER & STANDBY SWITCH TO OFF

Bass Prodigy™ Four:88

TUBE REPLACEMENT

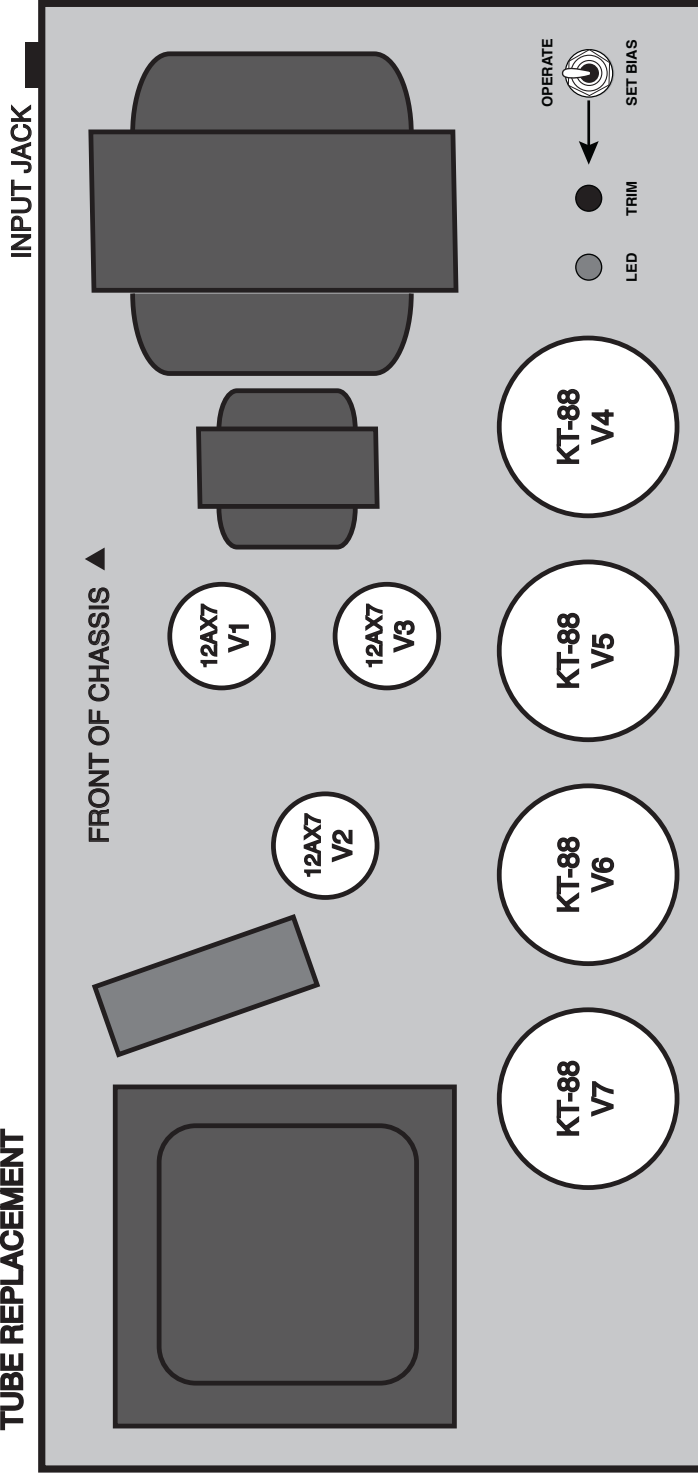

POWER TUBES
FULL = V4 - V7
HALF = V4, V7

PREAMP TUBES
V1A- 2nd Gain Stage
V1B- 1st Gain Stage
V2A&B- Driver/Phase Inverter
V3A&B- Driver 2nd Stages

TO MAINTAIN WARRANTY, USE MESA/BOOGIE® TUBES WHEN REPLACEMENT IS NECESSARY
 FOR CUSTOMER SUPPORT, PLEASE CALL 707-778-6565 MONDAY-THURSDAY 9-5 PST, OR EMAIL US AT INFO@MESABOOGIE.COM

FRONT PANEL: Bass Prodigy™

SWITCH
pt# 607204

6x KNOBS
PT# 408600

SWITCH
pt# 607233

2 x SWITCH
pt# 607231

2 x SWITCH
pt# 600626

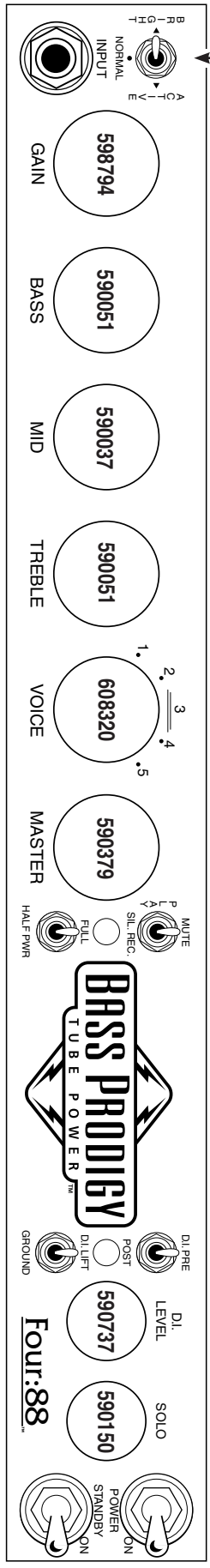

JACK
pt# 619112

SWITCH
pt# 607231

2x KNOBS
PT# 408601

REAR PANEL: Bass Prodigy™

CAUTION: Unplug power before servicing fuse or chassis

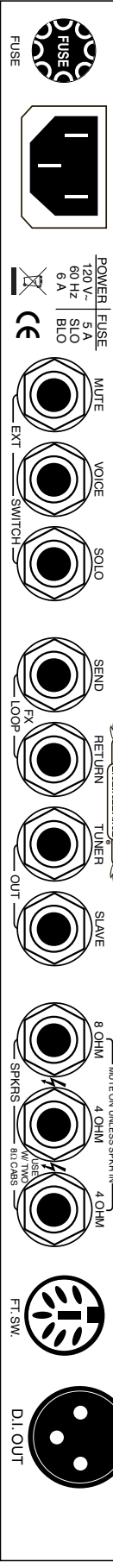

HOLDER
pt# 790355

JACK
pt# 613713

3x JACKS
pt# 619356

2x JACKS
pt# 619354

2x JACKS
pt# 619356

3x JACKS
pt# 619354

JACK
pt# 614608

JACK
pt# 620551

PATENTED
6,724,997

MESA/BOOGIE[®]

The Spirit of Art in Technology[™]

Thank you for trusting MESA/Boogie to be your amplifier company and we wish you many years of toneful enjoyment from this handbuilt all tube instrument.

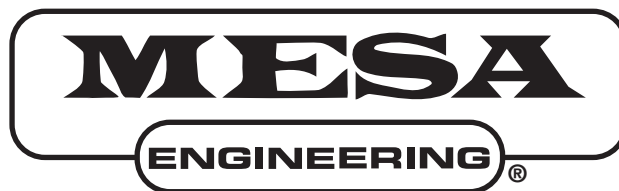

The Spirit of Art in Technology™



(707) 778-6565 FAX NO. (707) 765-1503

1317 Ross Street Petaluma, CA 94954

USA